

**PRODUCT DATASHEET**

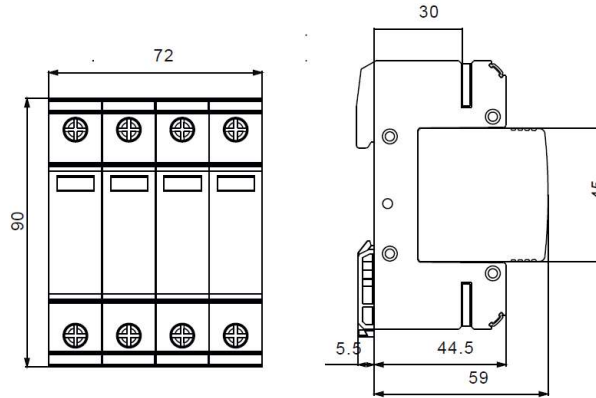

<b>Product Name :</b>	<i>Surge Protection Devices</i>		
<b>Product Codes :</b>	<i>VSP-1/100/B, VSP-1/20/D, VSP-1/40/C, VSP-1/50/B+C, VSP-2/100/B, VSP-2/20/D, VSP-2/40/C, VSP-2/50/B+C, VSP-3/100/B, VSP-3/20/D, VSP-3/40/C, VSP-3/50/B+C, VSP-4/100/B, VSP-4/20/D, VSP-4/40/C, VSP-4/50/B+C</i>		
<b>Technical Specifications:</b>			
<b>Model</b>	<i>CAU4-40</i>	<i>CAU4-30</i>	<i>CAU4-20</i>
<b>Highest continuous voltage (U c)</b>	<i>385/440V</i>	<i>385V</i>	<i>385/440V</i>
<b>Protection level (U p)</b>	<i>1,8kV</i>	<i>1,6kV</i>	<i>1,5kV</i>
<b>Number of Pole</b>	<i>1P, 1P+N/PE, 2P, 2P+N/PE, 3P, 3P+N/PE, 4P</i>		
<b>Voltage rating</b>	<i>230V, 3x230/400V</i>		
<b>Type of terminal</b>	<i>Elevator clamp</i>		
<b>Follow current extinguishing capability</b>	<i>10 kA/AC</i>		
<b>Follow current limitation</b>	<i>125A gG</i>		
<b>Mounting</b>	<i>on 7.5 x 35 mm size mounting rail (EN 50022)</i>		
<b>Integrated protection devices</b>	<i>Varistor, thermal fuse</i>		
<b>Operating temperature</b>	<i>-40° ... +55°</i>		
<b>Auxiliary status contact</b>	<i>Integrated (1 pc NO contact)</i>		
<b>Arresting signal</b>	<i>Red optical signal</i>		
<b>Terminal capacity</b>	<i>solid: 6 - 35 mm<sup>2</sup> flexible: 6 - 25 mm<sup>2</sup></i>		
<b>Flammability of housing</b>	<i>UL94-V0</i>		
<b>Standard and Quality Certificates</b>	<i>IEC 61643-1 CE, Ukr, WEEE</i>		

**Dimensions**



Panasonic Electric Works Elektrik.San. ve Tic. A.Ş.  
 Abdurrahmangazi Mah. Ebubekir Cad. No: 44 Sancaktepe / Istanbul Tel: 0216 564 55 55 Fax: 0216 564 55 44  
 ewtr.panasonic.com