

Panasonic









BUILDING AUTOMATION SYSTEMS PRODUCT CATALOGUE



Panasonic

- . Panasonic brings comfort, convenience, and realizes luxurious life.
- . Maximizes the energy efficiency to be eco-friendly to the environment.
- . Gives flexibility to provide safety and to meet various needs.



 Lighting	 Monitoring Systems
 Roller Blind - Shutter	 Remote Access
 Security Systems	 Intercom
 Heating, Ventilation, Air Conditioning Control	 Concierge



With its Panasonic Home Automation Systems, Panasonic continuously develops its range of solutions and products, and manufactures systems in line with KNX, one of the world's open standard for the control in both commercial and residential buildings.

From lighting, air conditioning and blind-shutter control to integration of security systems in a building or flat, Panasonic offers versatile solutions. While the system can be programmed in line with your requirements and the equipment of your building, you can always make additions and modifications in time as per newly arising needs.

Panasonic enables you to control comfort, energy saving, safety and security systems in any kind of building. It can be controlled either fully automatically or if you wish, centrally right from your desk, and even by your smartphone from outdoors.

Panasonic

User Benefits



Comfort & Convenience

Step into a much smarter life...

Panasonic combines technology with human touch and realizes more comfortable and convenient life space.

- By pushing the switches, all lights can be turned on and off.
- If you forget to turn the lights off, you are able to turn them off using your smartphone from outside.
- Various types of dimming controls will make your living space more comfortable.
- Time control function can also be realized to turn the lights on/off automatically when the time comes.
- With the presence sensors, lights can be automatically turned on.

Energy Efficiency

What makes a building “smart”?

A smart building is based on consuming the right energy at the right time.

Panasonic is an eco-friendly system and optimizes and minimizes energy usage.

- Sensors will save energy by turning the light off automatically.
- By setting the thermostat, temperatures are adjusted automatically so that room conditions can be maintained.
- Blind control function can support the temperature change that comes from sun position according to your windows.



Luxury

Beyond Luxury... It's Panasonic.

Who wouldn't want their home to be more relaxing, peaceful and comfortable? Set your imagination free and meet Panasonic and its high class atmosphere.

- Variety switch plate matches any kind of living space.
- Panasonic supports the DALI (Digital Addressable Lighting Interface) to provide flexible lighting fixture control.
- With the interface that you can install in your smart phone or tablets, you may remotely connect to your Panasonic Touch Panel.



Security & Flexibility

Safety is first...

No more "Have I left anything on at home?" worries... Panasonic will also provide safe and secure environment.

- Stream video of IP camera can be shown on your touch panel.
For instance, lobby could be checked from your room.
- If you have an adapted door/window opening sensor, Panasonic will remind you the door/window still open.
- Sensor also inform you the occurrence of defect like smoke or burglar.

Panasonic

User Interface

Now all buildings are smarter with Panasonic Switches...

From lighting, air conditioning and blind-shutter control to integration of security systems, Panasonic offers versatile solutions for residences as well as hotels, school buildings, hospitals and business centers. It can be used in perfect harmony with the enriched color and frame types of Panasonic Modular Series.

KNX MULTI FUNCTIONAL SWITCH



New Multis is now available in black



Thermostat
KNX Switches
Inox Frame



KNX Switches
Light Green
Frame



KNX Switches
Red Claret
Frame



KNX Switches
Inox Frame



KNX Switches
Black Frame

Frame

An exclusive and rich range of modular frame options provided by Ultima, Sistema and Optima models steer the decorations.

Cover Plate / Rocker

Different colored switching modules are distinctively combined in Italian style to appeal to those having a hard time to choose.

Modular Mechanism

Modular mechanisms developed for switch, socket, TV/DATA, dimmer, electronic products depending on use serve for the maximum satisfaction of the users.



Modular Wallbox and Mounting Frames

Halogen Free modular boxes suitable for walls varying as concrete and drywall and mounting frames suitable for use draw the borders of impeccability of modular series.

Panasonic Touch Panel

Stylish and functional...

It's Panasonic Touch Panel.

Everything is at the fingertips with Panasonic Touch Panel. Panasonic Touch Panel is designed as wall mounted tablet PC for home automation systems. It allows you to control each point of your home automation system from the interfaces customizable to the user's request. With its interface that you can install in mobile phone or smart tablet, you may remotely connect to your panel, and perform control and imaging.

- KNX devices can be controlled via touch panel
- Connection with IP Camera
- Scene control
- Connection with mobile phone and tablet

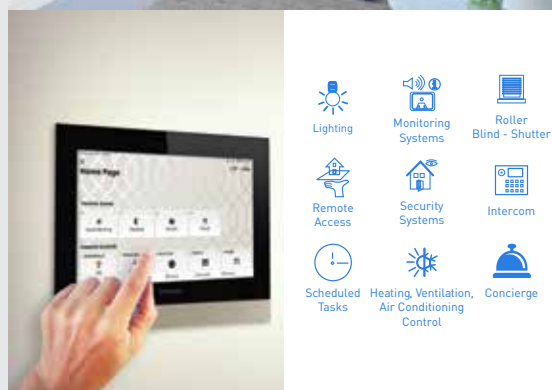

Remote Access

Everything is under control...

Smartphone can be used as a remote controller to activate lightings, blinds, and HVAC systems. Also access from the outside is possible to turn on/off the lights, as well as controlling HVAC systems to make your return more comfortable than ever.



Basic Functions



ALL ON / OFF

All on and off switch allows the user to turn all lights on or off. This can be used especially when you leave your home, and come back from outside.

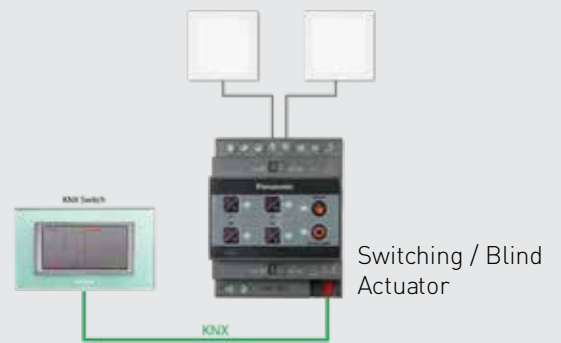
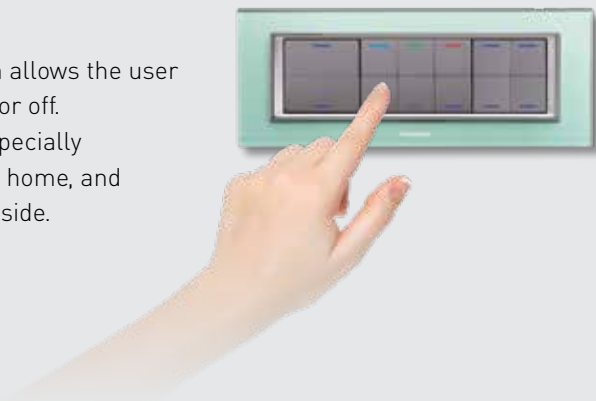

DIMMING CONTROL

Several different controlling options can be used to dim the lighting including 1-10V and DALI. A DALI-Gateway serves as the interface between the KNX installation in the building and the digital DALI lighting control system, and therefore unites the two most important building automation standards.



Panasonic combines technology with human touch...

SCENE LIGHTING

Using lighting scenes in a smart lighting or home automation system simplifies your routine by allowing you to activate multiple settings with one-button.



SENSOR & TIMER CONTROL

Sensors and timer control provides energy saving features and automatic control options for lighting control systems.



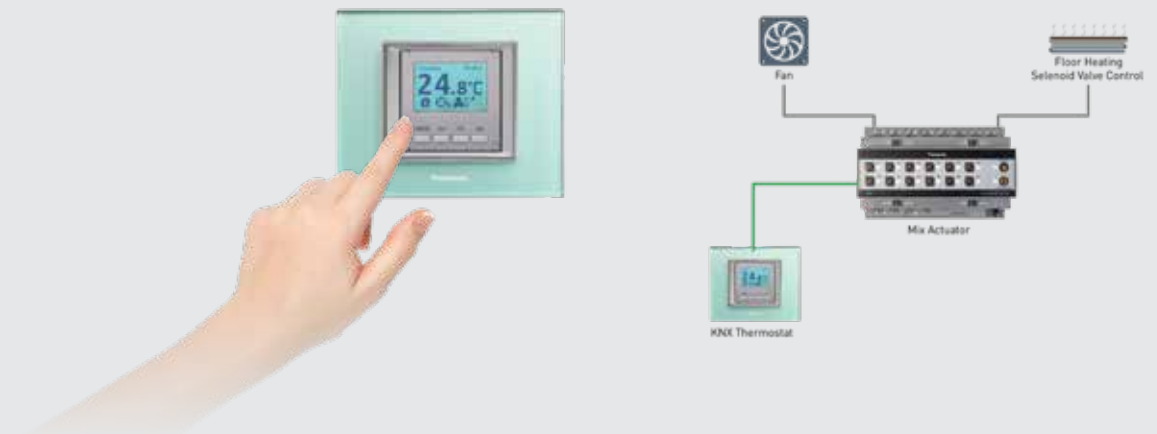

Panasonic provides efficient heating / ventilation systems...

TEMPERATURE CONTROL OF THE ROOM CAN BE DONE INDIVIDUALLY USING THERMOSTAT

By setting the suitable temperature into your thermostat, thermostat will activate accordingly to control your HVAC (Heating, Ventilation, Air Conditioning) system.

PLEASANT VENTILATION

Improves the air quality of the room by activating ventilation using the presence detectors information.

SENSOR & TIMER CONTROL

By using the information of the presence detector, weather station, and timer control, your room can be controlled more efficiently under different environments and settings.

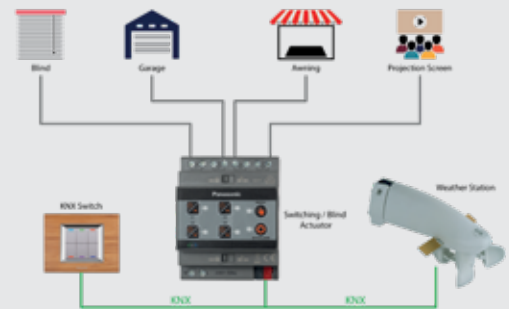

Utilizing the ambient environment, shades and slats are automatically controlled

CONTROL NATURAL LIGHTING

Roller shutters, blinds, and curtains can be controlled to prevent the room temperature to rise caused by the sunlight. Also by controlling the repositioning of the slats, this could also help decrease the brightness of the natural lighting.

SCENE CONTROL

Curtain / Shutter control provides comfort with simultaneous control of several engines as well as privacy, security and efficient lighting control. Thanks to Day Mode and Night Mode, the system can be arranged to open and close with sunrise and sunset.

SENSOR & TIMER CONTROL

By using the information of the presence detector, weather station, and timer control, sun protection can be realized which should make your room more comfortable. Besides, it contributes to energy saving especially in commercial buildings and buildings with glass facade. It prevents the sunlight from entering inside with automated activation of the shutter or sun blinds through the data received from outdoor sensors and ensures that air-conditioners run more efficiently, consume less energy, and decreases the maintenance cost of less-operating cooling systems in long-term.

Create your own world with Panasonic...

Security

- Connection with IP Camera
- Connection with Sensor

HVAC

- Room Temperature Control
- Pleasant Ventilation
- Sensor & Timer Control

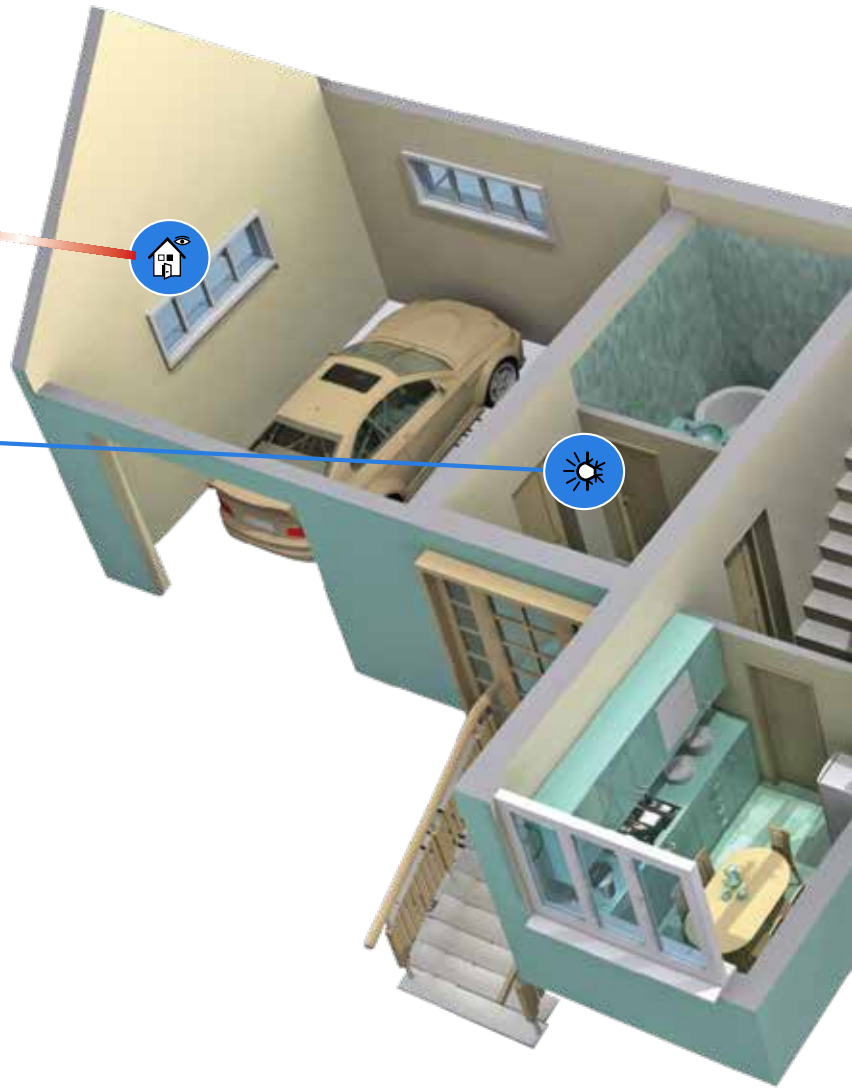

Lighting



Roller
Blind - Shutter



Security
Systems



Heating, Ventilation,
Air Conditioning
Control



Monitoring
Systems



Remote Access





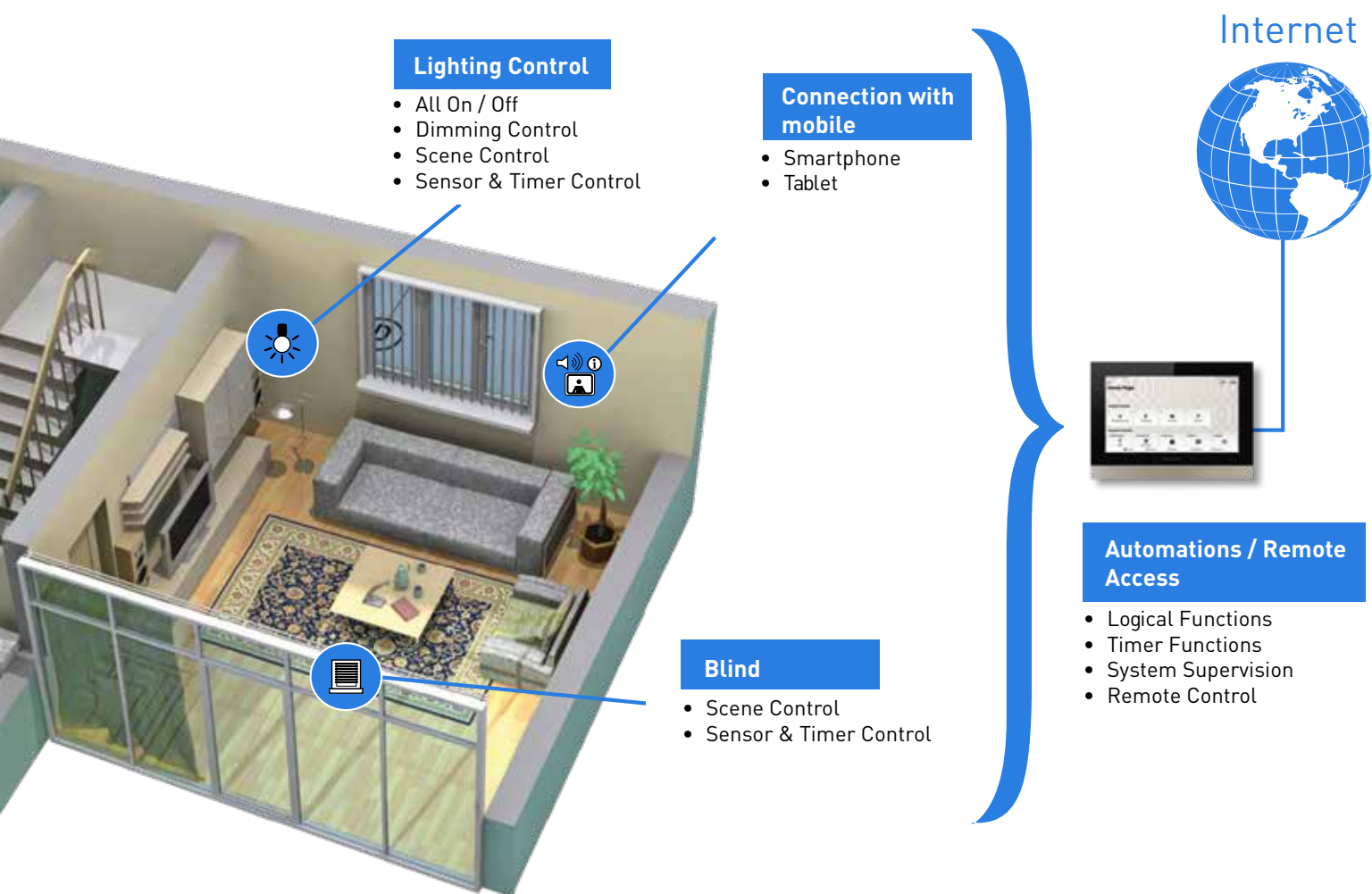

Intercom



Panasonic

Product range of PANASONIC



Page 16-19	
Touch Panel	
Page 20-47	
Switch	
Page 48-58	
Power Supply & Interface	
Page 59-67	
Actuator	
Page 68-73	
Sensor & Detector	

10.1" TOUCH PANEL

Smart Building Functions

Manage your smart building remotely if you wish.

In home and office spaces and galleries and general sites, you can centrally manage all of the smart home / smart building / automation functions from a single point. Control points can be located in screen as sketch, picture of the location or grid. Therefore a user-friendly interface provides ease of use for all ages. All of these functions can be utilized even from a distance by your mobile phone.

- Lighting • Dimming • Curtain - Shutter • Thermostat • Alarm - Security

Compose your own scenarios.

You can assign smart home functions to a single button, using Panasonic scenario editor, and activate the scenario with one touch. You can fictionalize time-dependent scenarios. It is possible to compose personal scenarios such as turn off the whole lighting system every evening at 11:30 p.m. turn on garden lighting every evening at 6:00 p.m. and turn off it every morning at 6:30 a.m.



Camera Display

Monitor your cameras instantly.

Images of IP cameras within the same network can be monitored live. After a proper IP configuration, footage can be displayed from your mobile phone or your tablet.

Alarm and Security

Use your own security system.

You can use indefinite security system without fee by adding products such as smoke detector, gas leak detector, flood detector and magnetic gate detector to system. It is possible to activate alarm before leaving home and then deactivate it with your personal password. In case of any alarm, the screen starts to give siren sound and security staff of the housing estate is warned. The relevant settings are sent to your mobile phone or tablet and shared as notification. In case of a proper configuration in your system, electricity, gas and water can be cut automatically. Past alarm notifications are recorded and can be monitored.



KNX TOUCH PANEL TP110 and KNX MOUNTING BOX MB110



■ MAIN FEATURES

- Smart Home Functions
 - Lighting control
 - Dimming control
 - RGB control
 - Shutter / Blind control
 - Thermostat control
- Scene Functions
 - Individual scene create
 - Time dependent scene management
 - KNX scene control
- Intercom Integration
 - Voice and video call
 - SIP support
 - Missed call log with video
 - Quick dial list
- Alarm and Security
 - Magnetic, smoke, earthquake, flooding, gas leakage, motion detector integration
 - NO and NC detector support
 - Detector fake alarm barrier
 - At home and outside alarm functions
 - IP camera visualization
- Remote Control Apps (iOS®/Android™)

■ PRODUCT CODES

PRODUCT	PRODUCT CODES
KNX TOUCH PANEL TP110	WRKT91115AR
KNX MOUNTING BOX MB110	WRKT93105AR

■ DIMENSIONS

• Touch Panel Device Front and Side Dimensions

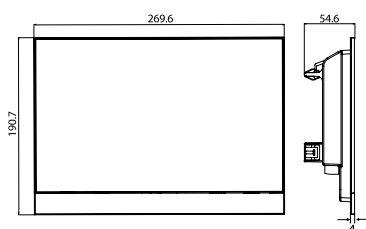

• Mounting Box Front and Side Dimensions

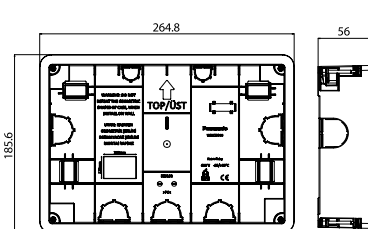

■ TECHNICAL DATA

Hardware Features	
Operating Voltage	12-24V
Power Consumption	18W or less
Recommended Power Supply and Permissible cable length	12V - 4,5A (per device) Maximum 100 m at $\phi 1.6$ or 2.0 mm ²
Operating Temperature	-5~50°C
Relative Humidity	0-90 %
LCD Size	10 Inch 1024x600
OS	Linux®
Interface	1 x 100 Mbit/s Ethernet port (LAN1) 1 x 100 Mbit/s Ethernet port (LAN2) 1 x USB 3 x Digital Inputs / 2 x Dry Contact Outputs
Ethernet Standards	IEEE 802.3u / IEEE 802.3 ab
Maximum Wire Length for Ethernet	100 m

Inputs	
Scanning voltage (Un) for Inputs	8-30V pulsed (depends on the power into the monitor)
Scanning current (In) for Inputs	0.1mA
Scanning current In at switch on for Inputs	Maximum 20 mA
Permissible cable length for Inputs	Maximum 100 m at $\phi 1.2$ or 1.2 mm ²

Outputs				
	Endurance	Condition	Inrush Current	Consumption
Resistance load	50,000 times	5A L/R=0	-	150 W
Inductive load	20,000 times	5A L/R=7 ms	5A	120 W
Motor load	6,000 times	1.5A, cos ϕ =0.4	15A / 80ms cos ϕ =0.7	330 VA

■ CONNECTION

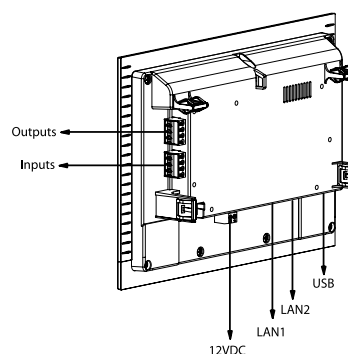

Panasonic

KNX IP INTERFACE IP100 and KNX IP INTERFACE I/O IP164



■ MAIN FEATURES

- Providing an IP connection to KNX TP
- Support KNXnet / IP tunneling function
- 4 IP tunneling connection with individual address
- IP filtering for tunneling connections
- Parameter setting via web interface
- Firmware update via web interface
- DIN rail
- ETS compatible
- Input and Output objects (only for IP164)
- No need for an additional power supply
- APDU length 15 byte
- KNXnet/IP, DHCP, AutoIP, HTTP, UDP/IP, TCP/IP, ARP, ICMP and IGMP protocol support

■ PRODUCT CODES

PRODUCT	PRODUCT CODES
KNX IP INTERFACE IP100	WRKT92105NC
KNX IP INTERFACE I/O IP164	WRKT92115NC

■ DIMENSIONS

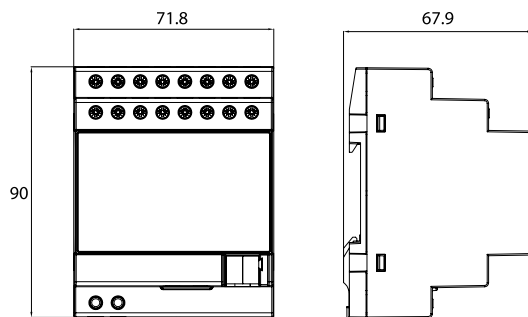

■ TECHNICAL DATA

Power	
Operating voltage	DC 21-32 V (from KNX bus)
Environmental conditions	
Ambient temperature	-5 C ... +45 C
Storage temperature	-10 C ... +55 C
Ambient humidity	5...93% (non-condensing)
Housing	
Dimensions (HxWxD)	90 mm x 71,8 mm x 65,8 mm
Mounting (IEC60715)	35 mm top-hat rail (TH35)
Mounting width	DIN rail 72mm (4 modules)
KNX bus connection	KNX connector (243-211 Wago)
IP connector	Ethernet (RJ45, female)
Input / Output (only IP164)	
Outputs	4 Latch Relay Outputs (16A-230VAC Resistive) (1200W-230VAC Tungsten)
Inputs	6 Dry Contact Digital Inputs
Electrical safety	
Protection type (IEC60529)	IP 20
Pollution degree (IEC60664)	2
Protection class (IEC61140)	II
Overvoltage category (IEC60664)	III

Panasonic Building Automation System Connection Diagram

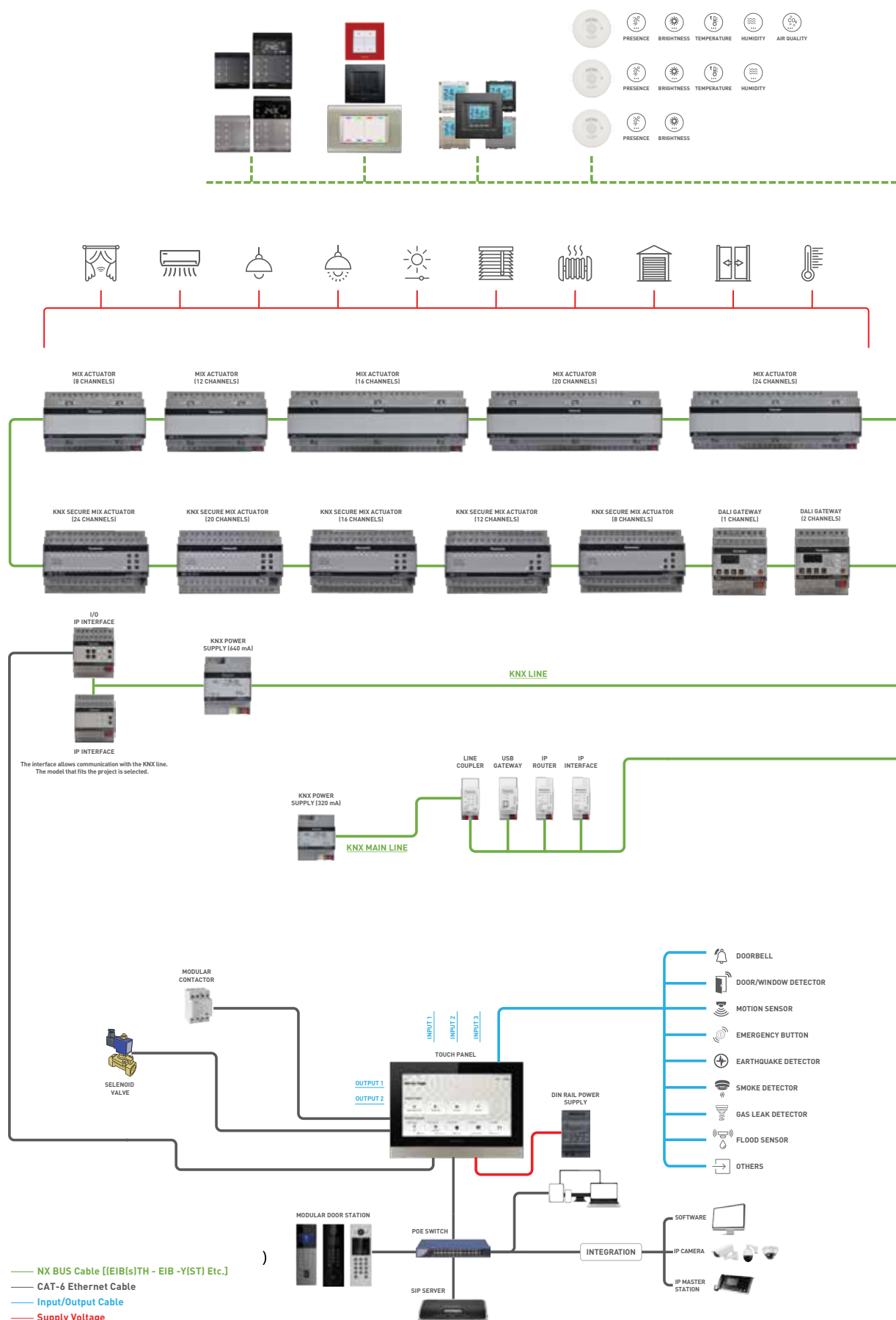



SWITCH



Modular



SWITCH Push Buttons

KNX Modular Switches

KNX Modular Push Button Multi
Color 1 Gang 2M



KNX Modular Push Button Multi
Color 2 Gang 2M



KNX Modular Push Button Multi
Color 3 Gang 3M



■ MAIN FEATURES

- Elevate your automation experience with our diverse range of KNX push buttons, available in 1 gang, 2 gang, and 3 gang configurations, allowing you to customize your control to fit seamlessly into your lifestyle.
- Change the ambiance of your place with each key featuring two multi-color LEDs.
- Control your KNX system with the push buttons, empowering you to effortlessly command actuators, dim, turn on and off lights, move blinds up and down, and even save and recall your favorite light scenes.
- Unlock the full potential by using push buttons to send temperature, priority, percentage, and HVAC operation mode values.
- Enjoy the convenience of saving scene functions with a simple 3-4 second press, making your place truly responsive to your needs.

- Personalize your experience with customizable behaviors through both short and long key depressions.
- Introducing the advanced WRKT64215NC, WRKT64225NC, and WRKT64335NC models, equipped with on-board temperature and humidity sensors—taking smart home control to a whole new level. Elevate your environment with precision and style.
- Can be located into all frames of Thea Modular Series; Optima, Sistema and Ultima.

■ FUNCTIONS

- Switching Control
- Dimming Control
- Blinds Control
- Value Dimming Control
- Value Transmitter Control

■ TECHNICAL DATA

Programming Mode	S Mode
Power Supply	21 to 32 V DC via KNX Bus
Current Draw From Bus Voltage	Max 10 mA
Bus Connection	Bus Terminal
Type of Protection	IP 20 to EN 60529
Degree of Pollution	2 to IEC 6066-1
Protection Class	Class III to IEC 61140
Overtoltage Class	Class III to IEC 60664-1
Temperature Range	Operation -5 °C...+45 °C Storage -10 °C...+55 °C Transport -25 °C...+70 °C
Relative Humidity	0% to 100%
Relative Humidity Measurements (for models with sensors)	-0 °C...+45 °C
Cable Type	Twisted Pair

■ PRODUCT CODES

PRODUCT	PRODUCT CODES
KNX Modular Push Button Multi Color 1 Gang 2M	WRKT63215NC
KNX Modular Push Button Multi Color 2 Gang 2M	WRKT63225NC
KNX Modular Push Button Multi Color 3 Gang 3M	WRKT63335NC
KNX Modular Push Button Multi Color+Temp 1 Gang 2M	WRKT64215NC
KNX Modular Push Button Multi Color+Temp 2 Gang 2M	WRKT64225NC
KNX Modular Push Button Multi Color+Temp 3 Gang 3M	WRKT64335NC

■ DIMENSIONS

1 GANG (2M) / 2 GANG (2M)

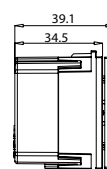
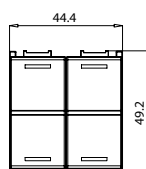

3 GANG (3M)

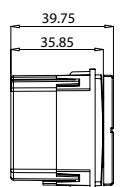
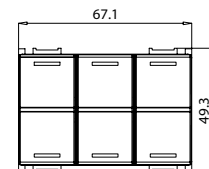

SWITCH Push Buttons

KNX Modular Switches

KNX Modular Push Button Multi
Color 4 Gang 2M



KNX Modular Push Button Multi
Color 4 Gang 4M



■ MAIN FEATURES

- Elevate your automation experience with our cutting-edge KNX push buttons, now available in sleek 4-gang configurations.
- Change the ambiance of your place with each key featuring two multi-color LEDs.
- Control your KNX system with the push buttons, empowering you to effortlessly command actuators, dim, turn on and off lights, move blinds up and down, and even save and recall your favorite light scenes.
- Unlock the full potential by using push buttons to send temperature, priority, percentage, and HVAC operation mode values.

- Enjoy the convenience of saving scene functions with a simple 3-4 second press, making your place truly responsive to your needs
- Personalize your experience with customizable behaviors through both short and long key depressions.
- Introducing the advanced WRKT64245NC and WRKT64445NC models, equipped with on-board temperature and humidity sensors—taking smart home control to a whole new level. Elevate your environment with precision and style.

■ FUNCTIONS

- Switching Control
- Dimming Control
- Blinds Control
- Value Dimming Control
- Value Transmitter Control

■ TECHNICAL DATA

Programming Mode	S Mode
Power Supply	21 to 32 V DC via KNX Bus
Current Draw From Bus Voltage	Max 10 mA
Bus Connection	Bus Terminal
Type of Protection	IP 20 to EN 60529
Degree of Pollution	2 to IEC 6066-1
Protection Class	Class III to IEC 61140
Overvoltage Class	Class III to IEC 60664-1
Temperature Range	Operation -5 °C...+45 °C Storage -10 °C...+55 °C Transport -25 °C...+70 °C
Relative Humidity	0% to 100%
Relative Humidity Measurements (for models with sensors)	-0 °C...+45 °C
Cable Type	Twisted Pair

■ PRODUCT CODES

PRODUCT	PRODUCT CODES
KNX Modular Push Button Multi Color 4 Gang 2M	WRKT63245NC
KNX Modular Push Button Multi Color 4 Gang 4M	WRKT63445NC
KNX Modular Push Button Multi Color+Temp 4 Gang 2M	WRKT64245NC
KNX Modular Push Button Multi Color+Temp 4 Gang 4M	WRKT64445NC

■ DIMENSIONS

4 GANG (2M)

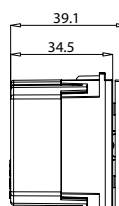
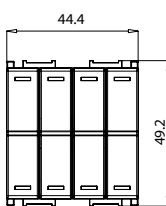

4 GANG (4M)

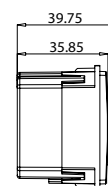
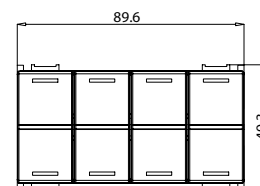

Panasonic

SWITCH

Frame and Cover Color Alternatives

Optima



Optima Color Alternatives

OPAQUE



OPAQUE
WHITE



BEIGE

METALLIC



METALLIC
WHITE



BLACK



DARK GRAY



ANTHRACITE



DORE

Frame Alternatives



2M



2/3M



3M



4M



7M



2x2M



3x2M



4x2M

SWITCH

Frame and Cover Color Alternatives

Product Codes

■ OPTIMA FRAMES PRODUCT CODES

COVER COLOR	2M FRAME	2/3M FRAME	3M FRAME	4M FRAME	7M FRAME
Anthracite	WVTF0840-1AN	WVTF0842-1AN	WVTF0843-1AN	WVTF0844-1AN	WVTF0847-1AN
Dore	WVTF0840-1DR	WVTF0842-1DR	WVTF0843-1DR	WVTF0844-1DR	WVTF0847-1DR
Dark Gray	WVTF0840-1DG	WVTF0842-1DG	WVTF0843-1DG	WVTF0844-1DG	WVTF0847-1DG
Beige	WVTF0840-1BG	WVTF0842-1BG	WVTF0843-1BG	WVTF0844-1BG	WVTF0847-1BG
Metallic White	WVTF0840-1MW	WVTF0842-1MW	WVTF0843-1MW	WVTF0844-1MW	WVTF0847-1MW
Opaque White	WVTF0840-1WH	WVTF0842-1WH	WVTF0843-1WH	WVTF0844-1WH	WVTF0847-1WH
Black	WVTF0840-1BL	WVTF0842-1BL	WVTF0843-1BL	WVTF0844-1BL	WVTF0847-1BL

COVER COLOR	2x2M FRAME	3x2M FRAME	4x2M FRAME
Anthracite	WVTF0848-1AN	WVTF0849-1AN	WVTF0850-1AN
Dore	WVTF0848-1DR	WVTF0849-1DR	WVTF0850-1DR
Dark Gray	WVTF0848-1DG	WVTF0849-1DG	WVTF0850-1DG
Beige	WVTF0848-1BG	WVTF0849-1BG	WVTF0850-1BG
Metallic White	WVTF0848-1MW	WVTF0849-1MW	WVTF0850-1MW
Opaque White	WVTF0848-1WH	WVTF0849-1WH	WVTF0850-1WH
Black	WVTF0848-1BL	WVTF0849-1BL	WVTF0850-1BL

Panasonic

SWITCH Frame and Cover Color Alternatives

Sistema



Sistema Color Alternatives

METALLIC



INOX

INOX MATT

CHROME

CHROME
MATT

UNA

ANTIQUE

GOLD

Frame Alternatives



2M

3M

4M

7M



2x2M

3x2M

4x2M

SWITCH

Frame and Cover Color Alternatives

Product Codes

■ SISTEMA FRAMES PRODUCT CODES

FRAME COLOR	2M FRAME	3M FRAME	4M FRAME	7M FRAME
Antique - Dore	WVTF1840-5AQ	WVTF1843-5AQ	WVTF1844-5AQ	WVTF1847-5AQ
Antique - Black	WVTF1840-5AY	WVTF1843-5AY	WVTF1844-5AY	WVTF1847-5AY
Chrome - Dark Gray	WVTF1840-5KF	WVTF1843-5KF	WVTF1844-5KF	WVTF1847-5KF
Chrome - Metallic White	WVTF1840-5CH	WVTF1843-5CH	WVTF1844-5CH	WVTF1847-5CH
Chrome Matt - Dark Gray	WVTF1840-5KD	WVTF1843-5KD	WVTF1844-5KD	WVTF1847-5KD
Chrome Matt - Metallic White	WVTF1840-5CM	WVTF1843-5CM	WVTF1844-5CM	WVTF1847-5CM
Gold - Dore	WVTF1840-5GL	WVTF1843-5GL	WVTF1844-5GL	WVTF1847-5GL
Gold - Black	WVTF1840-5GS	WVTF1843-5GS	WVTF1844-5GS	WVTF1847-5GS
Inox - Dark Gray	WVTF1840-5IG	WVTF1843-5IG	WVTF1844-5IG	WVTF1847-5IG
Inox - Metallic White	WVTF1840-5IN	WVTF1843-5IN	WVTF1844-5IN	WVTF1847-5IN
Inox Matt - Dore	WVTF1840-5IM	WVTF1843-5IM	WVTF1844-5IM	WVTF1847-5IM
Inox Matt - Metallic White	WVTF1840-5IB	WVTF1843-5IB	WVTF1844-5IB	WVTF1847-5IB
Una - Dark Gray	WVTF1840-5UN	WVTF1843-5UN	WVTF1844-5UN	WVTF1847-5UN
Una - Metallic White	WVTF1840-5UW	WVTF1843-5UW	WVTF1844-5UW	WVTF1847-5UW

FRAME COLOR	2x2M FRAME	3x2M FRAME	4x2M FRAME
Antique - Dore	WVTF1848-5AQ	WVTF1849-5AQ	WVTF1850-5AQ
Antique - Black	WVTF1848-5AY	WVTF1849-5AY	WVTF1850-5AY
Chrome - Dark Gray	WVTF1848-5KF	WVTF1849-5KF	WVTF1850-5KF
Chrome - Metallic White	WVTF1848-5CH	WVTF1849-5CH	WVTF1850-5CH
Chrome Matt - Dark Gray	WVTF1848-5KD	WVTF1849-5KD	WVTF1850-5KD
Chrome Matt - Metallic White	WVTF1848-5CM	WVTF1849-5CM	WVTF1850-5CM
Gold - Dore	WVTF1848-5GL	WVTF1849-5GL	WVTF1850-5GL
Gold - Black	WVTF1848-5GS	WVTF1849-5GS	WVTF1850-5GS
Inox - Dark Gray	WVTF1848-5IG	WVTF1849-5IG	WVTF1850-5IG
Inox - Metallic White	WVTF1848-5IN	WVTF1849-5IN	WVTF1850-5IN
Inox Matt - Dore	WVTF1848-5IM	WVTF1849-5IM	WVTF1850-5IM
Inox Matt - Metallic White	WVTF1848-5IB	WVTF1849-5IB	WVTF18450-5IB
Una - Dark Gray	WVTF1848-5UN	WVTF1849-5UN	WVTF1850-5UN
Una - Metallic White	WVTF1848-5UW	WVTF1849-5UW	WVTF1850-5UW

Panasonic

SWITCH Frame and Cover Color Alternatives

Ultima



Ultima Color Alternatives

METALLIC



INOX



CHROME



GOLD



UNA

ELOXAL



SILVER



BRONZE



BLACK

GLASS



WHITE



LIGHT GREEN



CLARET RED



BLACK

WOOD



BAMBOO



WENGE



WALNUT

Frame Alternatives



2M



2/3M



3M



4M



7M



2x2M



3x2M



4x2M

SWITCH Frame and Cover Color Alternatives

Product Codes

■ ULTIMA FRAMES PRODUCT CODES

FRAME COLOR	2M FRAME	2/3M FRAME	3M FRAME	4M FRAME	7M FRAME
WOOD - Walnut	WVTF2840-5WW	WVTF2842-5WW	WVTF2843-5WW	WVTF2844-5WW	WVTF2847-5WW
WOOD - Wenge	WVTF2840-5WV	WVTF2842-5WV	WVTF2843-5WV	WVTF2844-5WV	WVTF2847-5WV
WOOD - Bamboo	WVTF2840-5WB	WVTF2842-5WB	WVTF2843-5WB	WVTF2844-5WB	WVTF2847-5WB
ELOXAL - Silver	WVTF2840-5AS	WVTF2842-5AS	WVTF2843-5AS	WVTF2844-5AS	WVTF2847-5AS
ELOXAL - Bronze	WVTF2840-5AR	WVTF2842-5AR	WVTF2843-5AR	WVTF2844-5AR	WVTF2847-5AR
ELOXAL - Black	WVTF2840-5AB	WVTF2842-5AB	WVTF2843-5AB	WVTF2844-5AB	WVTF2847-5AB
GLASS - White	WVTF2840-5GW	WVTF2842-5GW	WVTF2843-5GW	WVTF2844-5GW	WVTF2847-5GW
GLASS - Light Green	WVTF2840-5GG	WVTF2842-5GG	WVTF2843-5GG	WVTF2844-5GG	WVTF2847-5GG
GLASS - Claret Red	WVTF2840-5GC	WVTF2842-5GC	WVTF2843-5GC	WVTF2844-5GC	WVTF2847-5GC
GLASS - Black	WVTF2840-5GB	WVTF2842-5GB	WVTF2843-5GB	WVTF2844-5GB	WVTF2847-5GB
METALLIC - Chrome	WVTF2840-5MC	WVTF2842-5MC	WVTF2843-5MC	WVTF2844-5MC	WVTF2847-5MC
METALLIC - Inox	WVTF2840-5MI	WVTF2842-5MI	WVTF2843-5MI	WVTF2844-5MI	WVTF2847-5MI
METALLIC - Gold	WVTF2840-5MG	WVTF2842-5MG	WVTF2843-5MG	WVTF2844-5MG	WVTF2847-5MG
METALLIC - Una	WVTF2840-5MU	WVTF2842-5MU	WVTF2843-5MU	WVTF2844-5MU	WVTF2847-5MU

FRAME COLOR	2x2M FRAME	3x2M FRAME	4x2M FRAME
WOOD - Walnut	WVTF2848-5WW	WVTF2849-5WW	WVTF2850-5WW
WOOD - Wenge	WVTF2848-5WV	WVTF2849-5WV	WVTF2850-5WV
WOOD - Bamboo	WVTF2848-5WB	WVTF2849-5WB	WVTF2850-5WB
ELOXAL - Silver	WVTF2848-5AS	WVTF2849-5AS	WVTF2850-5AS
ELOXAL - Bronze	WVTF2848-5AR	WVTF2849-5AR	WVTF2850-5AR
ELOXAL - Black	WVTF2848-5AB	WVTF2849-5AB	WVTF2850-5AB
GLASS - White	WVTF2848-5GW	WVTF2849-5GW	WVTF2850-5GW
GLASS - Light Green	WVTF2848-5GG	WVTF2849-5GG	WVTF2850-5GG
GLASS - Claret Red	WVTF2848-5GC	WVTF2849-5GC	WVTF2850-5GC
GLASS - Black	WVTF2848-5GB	WVTF2849-5GB	WVTF2850-5GB
METALLIC - Chrome	WVTF2848-5MC	WVTF2849-5MC	WVTF2850-5MC
METALLIC - Inox	WVTF2848-5MI	WVTF2849-5MI	WVTF2850-5MI
METALLIC - Gold	WVTF2848-5MG	WVTF2849-5MG	WVTF2850-5MG
METALLIC - Una	WVTF2840-5MU	WVTF2843-5MU	WVTF2850-5MU

Panasonic

ACCESSORIES

Color Alternatives

■ WHITE



■ BEIGE



■ METALLIC WHITE



■ DORE

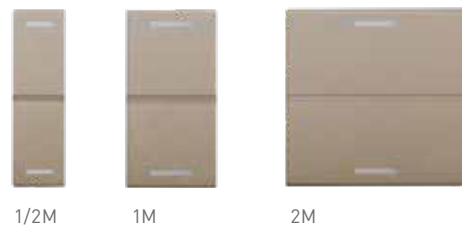

■ ANTHRACITE



■ DARK GRAY



■ BLACK



Full Range



LED Colors



BLUE CYAN GREEN MAGENTA RED

ACCESSORIES

Plastic Button Cover Pcs Table

KNX MODULAR SWITCH				PLASTIC BUTTON COVER		
				1/2M WRKT84004XX	1M WRKT84014XX	2M WRKT84024XX
WRKT63215NC	KNX Modular Push Button Multi Color 1 Gang 2M	2M	1 GANG			1 pcs
WRKT63225NC	KNX Modular Push Button Multi Color 2 Gang 2M	2M	2 GANG		2 pcs	
WRKT63245NC	KNX Modular Push Button Multi Color 4 Gang 2M	2M	4 GANG	4 pcs		
WRKT63335NC	KNX Modular Push Button Multi Color 3 Gang 3M	3M	3 GANG		3 pcs	
WRKT63445NC	KNX Modular Push Button Multi Color 4 Gang 4M	4M	4 GANG		4 pcs	
WRKT64215NC	KNX Modular Push Button Multi Color+Temp 1 Gang 2M	2M	1 GANG			1 pcs
WRKT64225NC	KNX Modular Push Button Multi Color+Temp 2 Gang 2M	2M	2 GANG		2 pcs	
WRKT64245NC	KNX Modular Push Button Multi Color+Temp 4 Gang 2M	2M	4 GANG			
WRKT64335NC	KNX Modular Push Button Multi Color+Temp 3 Gang 3M	3M	3 GANG		3 pcs	
WRKT64445NC	KNX Modular Push Button Multi Color+Temp 4 Gang 4M	4M	4 GANG		4 pcs	

COLOR CODE	
XX	EXPLANATION
WH	WHITE
MW	METALLIC WHITE
BG	BEIGE
DR	DORE
AN	ANTHRACITE
DG	DARK GRAY
BL	BLACK

■ BUTTON COVER PRODUCT CODES

COVER COLOR	1/2 M	1M	2M
White	WRKT84004WH	WRKT84014WH	WRKT84024WH
Beige	WRKT84004BG	WRKT84014BG	WRKT84024BG
Metallic White	WRKT84004MW	WRKT84014MW	WRKT84024MW
Dark Gray	WRKT84004DG	WRKT84014DG	WRKT84024DG
Dore	WRKT84004DR	WRKT84014DR	WRKT84024DR
Anthracite	WRKT84004AN	WRKT84014AN	WRKT84024AN
Black	WRKT84004BL	WRKT84014BL	WRKT84 024BL



Panasonic

ACCESSORIES

Using Mechanism and Button Cover

2x1 / 1 GANG (2M)
WRKT63215NC



2M
WRKT84024XX

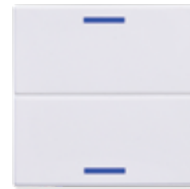

x1

4x2 / 2 GANG (2M)
WRKT63225NC



1M
WRKT84014XX



x2

8x4 / 4 GANG (2M)
WRKT64245NC



1/2M
WRKT84004XX



x4

6x3 / 3 GANG (3M)
WRKT63335NC



1M
WRKT84014XX



x3

8x4 / 4 GANG (4M)
WRKT64445NC



1M
WRKT84014XX



x4

ACCESSORIES

Mounting Frames

2M MOUNTING FRAMES



2/3M MOUNTING FRAME



3M MOUNTING FRAME



4M MOUNTING FRAME



7M MOUNTING FRAME



■ MOUNTING FRAMES PRODUCT CODES

PRODUCT	2M	2/3M	3M	4M	7M
Mounting Frame Metal	WVTC0732-4NC	WVTC0733-4NC	WVTC0734-4NC	WVTC0735-4NC	WVTC0736-4NC
Mounting Frame (With Claw)	WVTC0730-4NC	WVTC0737-4NC			
Mounting Frame (Ultima)	WVTC0731-4NC				

■ BOXES PRODUCT CODES

PRODUCT	2M	3M	4M	7M
Hollow Wall Box, Flush Mount	WVTC0780-4NC	WVTC0781-4NC	WVTC0782-4NC	WVTC0783-4NC
Hollow Wall Box, for Plasterboard	WVTC0784-4NC	WVTC0785-4NC	WVTC0786-4NC	WVTC0787-4NC

Panasonic

ACCESSORIES Norm

Mounting Boxes

2M HOLLOW WALL BOX



WVTC07804

2M HOLLOW WALL BOX



WVTC07844

2M HOLLOW WALL BOX



90926006

3M HOLLOW WALL BOX



WVTC07814

3M HOLLOW WALL BOX



WVTC07854

WALL BOX -
DEEP AND EXTENDABLE



90926001

4M HOLLOW WALL BOX



WVTC07824

4M HOLLOW WALL BOX



WVTC07864

7M HOLLOW WALL BOX



WVTC07834

7M HOLLOW WALL BOX



WVTC07874

TECHNICAL INFORMATION

Frames

Frame Dimensions

■ OPTIMA FRAMES

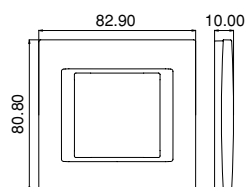

2M

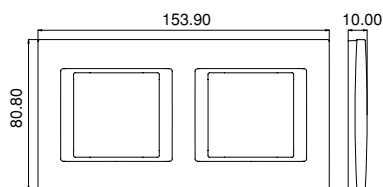

2x2M

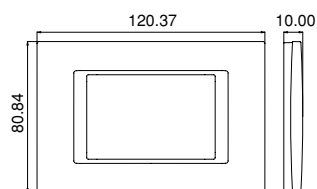

3M

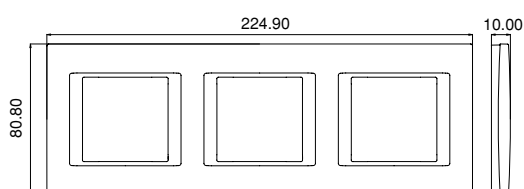

3x2M

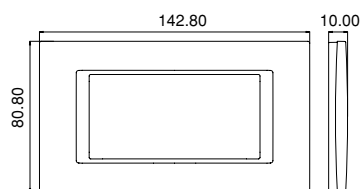

4M

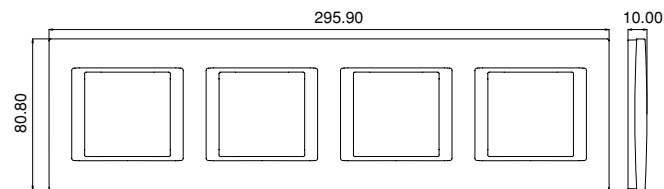

4x2M

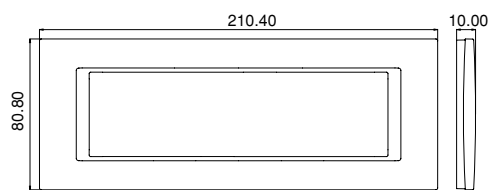

7M

TECHNICAL INFORMATION Frames

Frame Dimensions

■ SISTEMA FRAMES

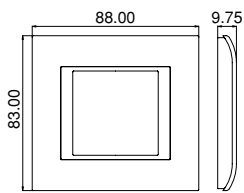

2M

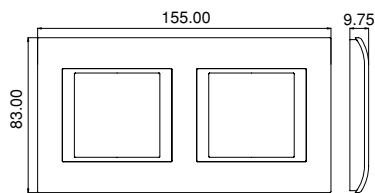

2x2M

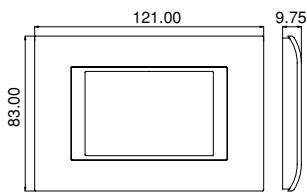

3M

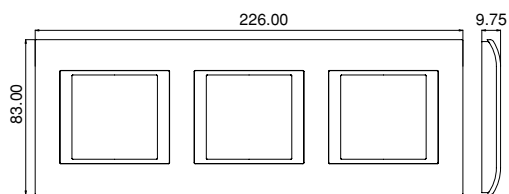

3x2M

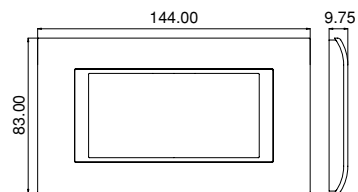

4M

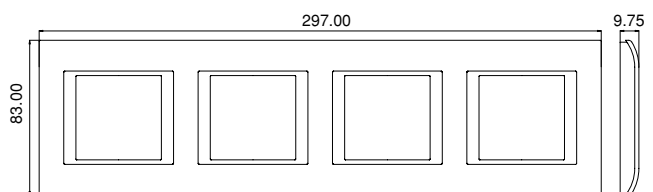

4x2M

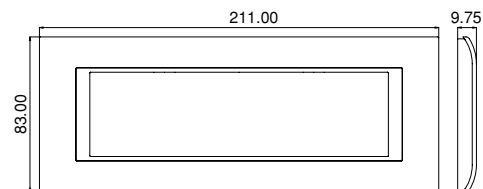

7M

TECHNICAL INFORMATION

Frames

Frame Dimensions

■ ULTIMA FRAMES

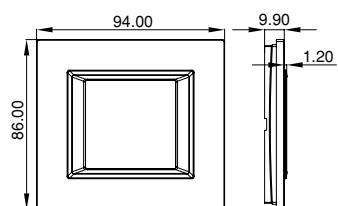

2M

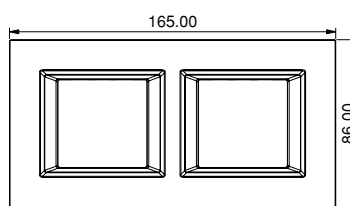

2x2M

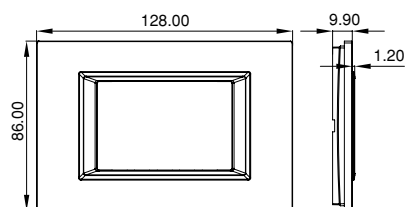

3M

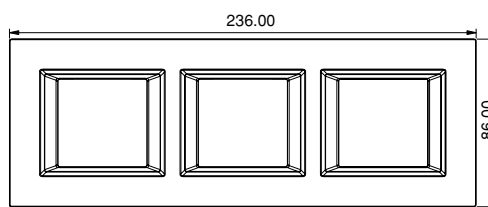

3x2M

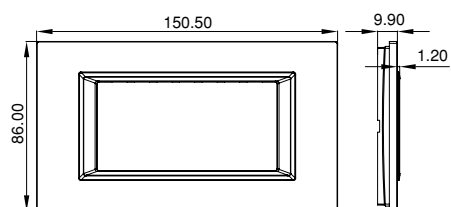

4M

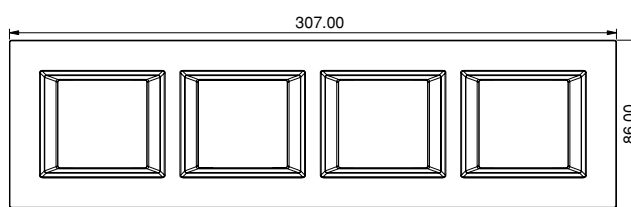

4x2M

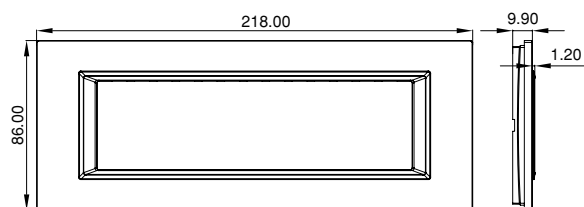

7M

TECHNICAL INFORMATION Accessories

Mounting Frame Dimensions

2M

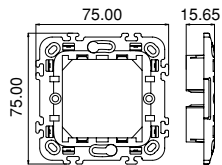

3M

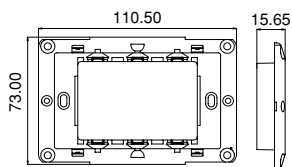

4M

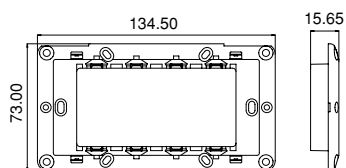

7M

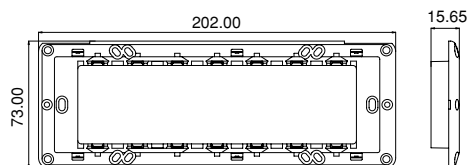

Wall Box Dimensions

HOLLOW WALL MOUNT

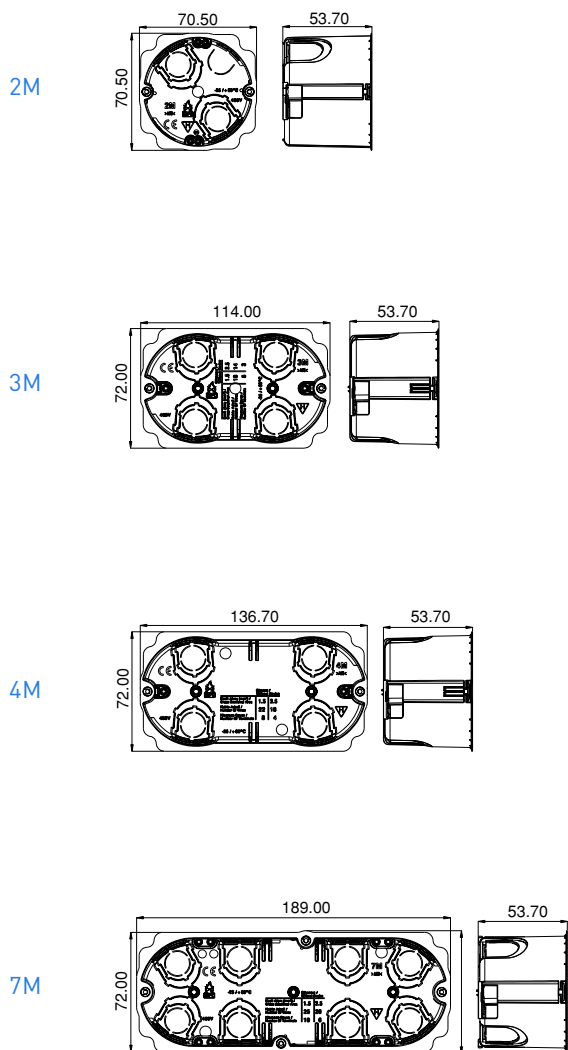

WALL MOUNT

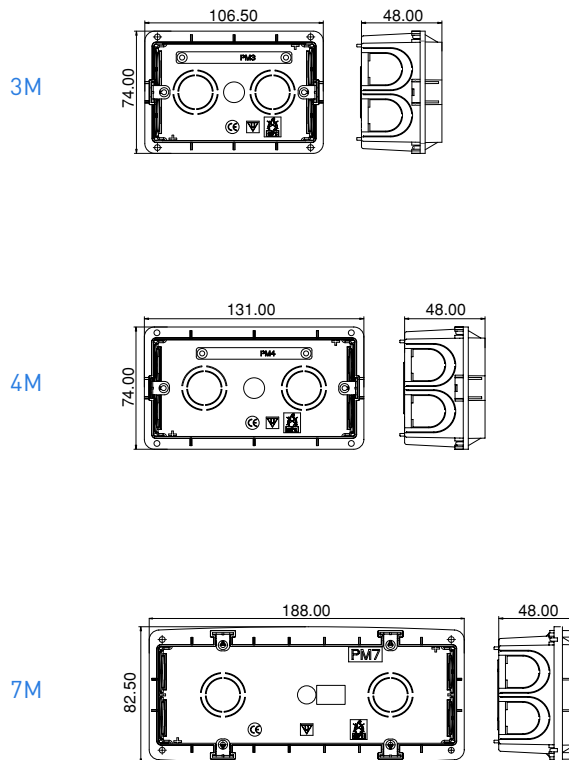

Panasonic

TECHNICAL INFORMATION Modular

Mounting Modular

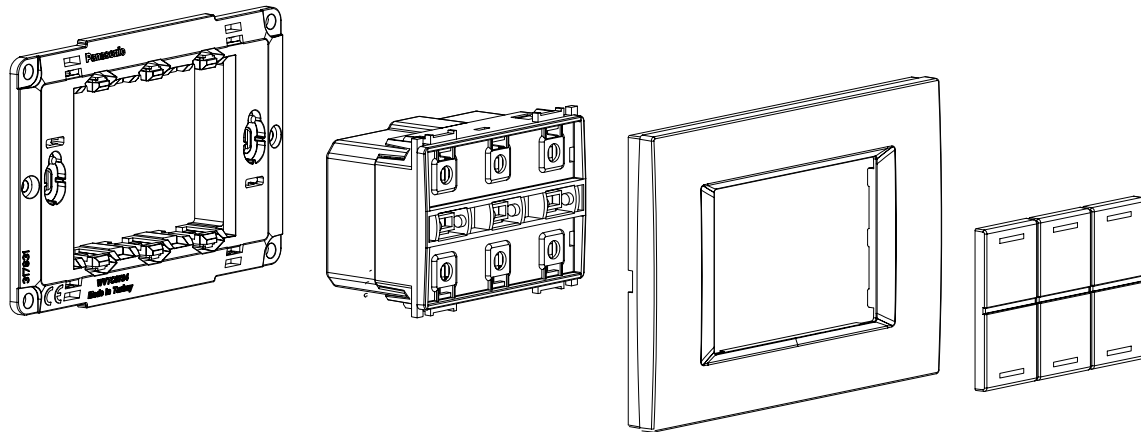

Boxes

Mounting Frames

Buttons

Frames

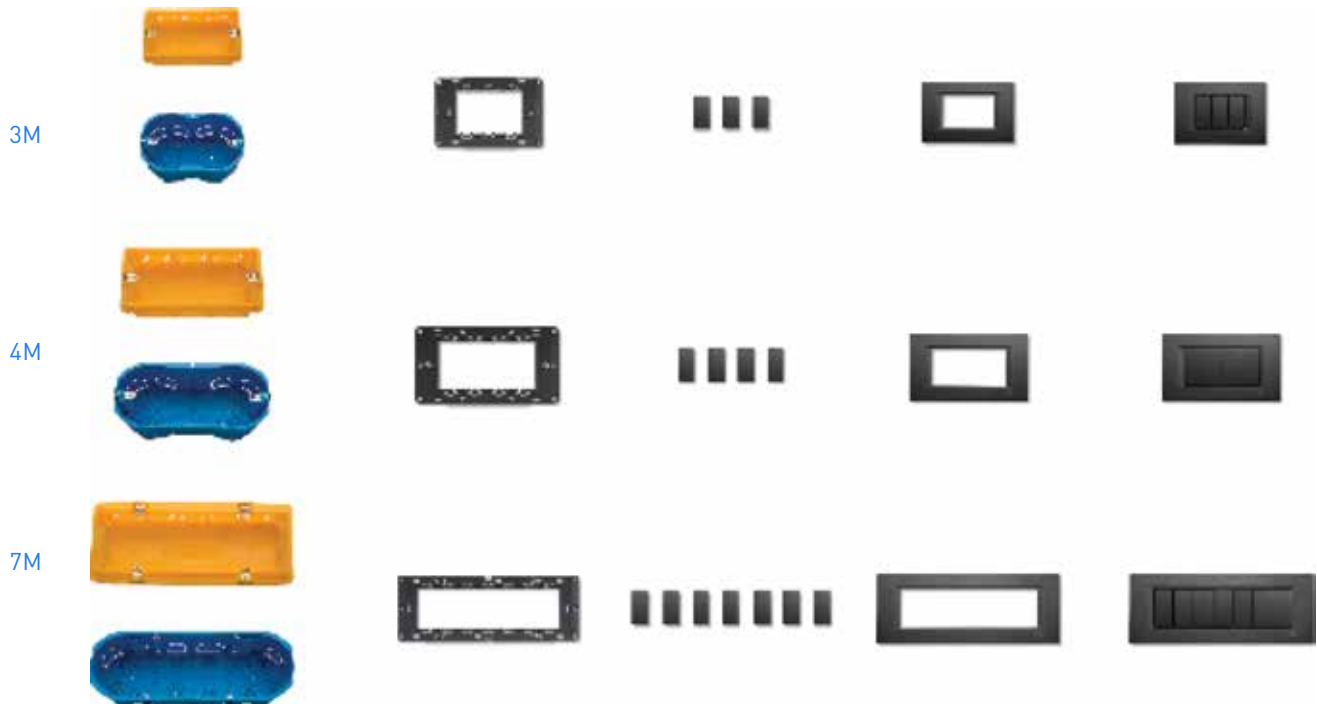

TECHNICAL INFORMATION

Norm

Mounting Norm

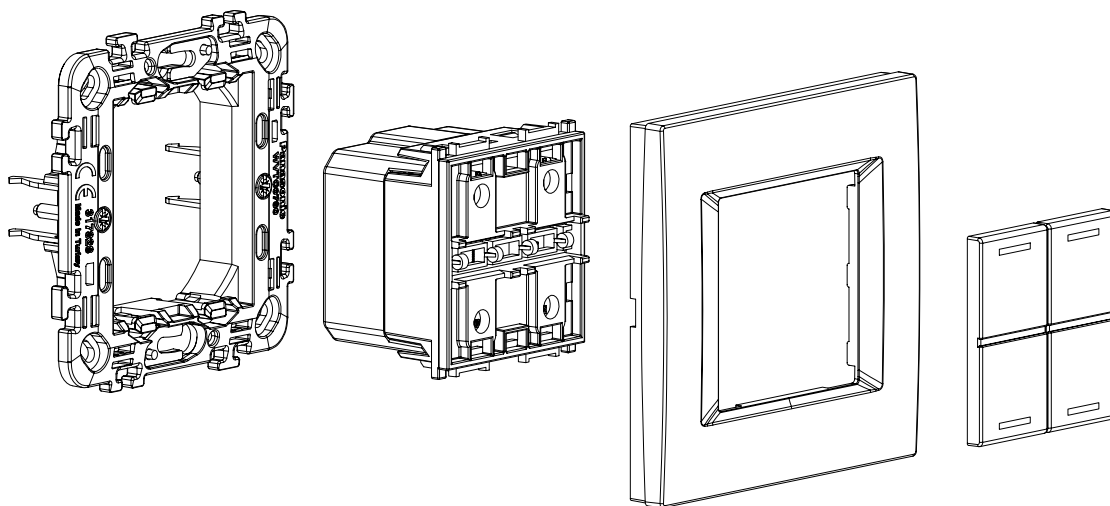

Boxes

Mounting Frames

Buttons

Frames

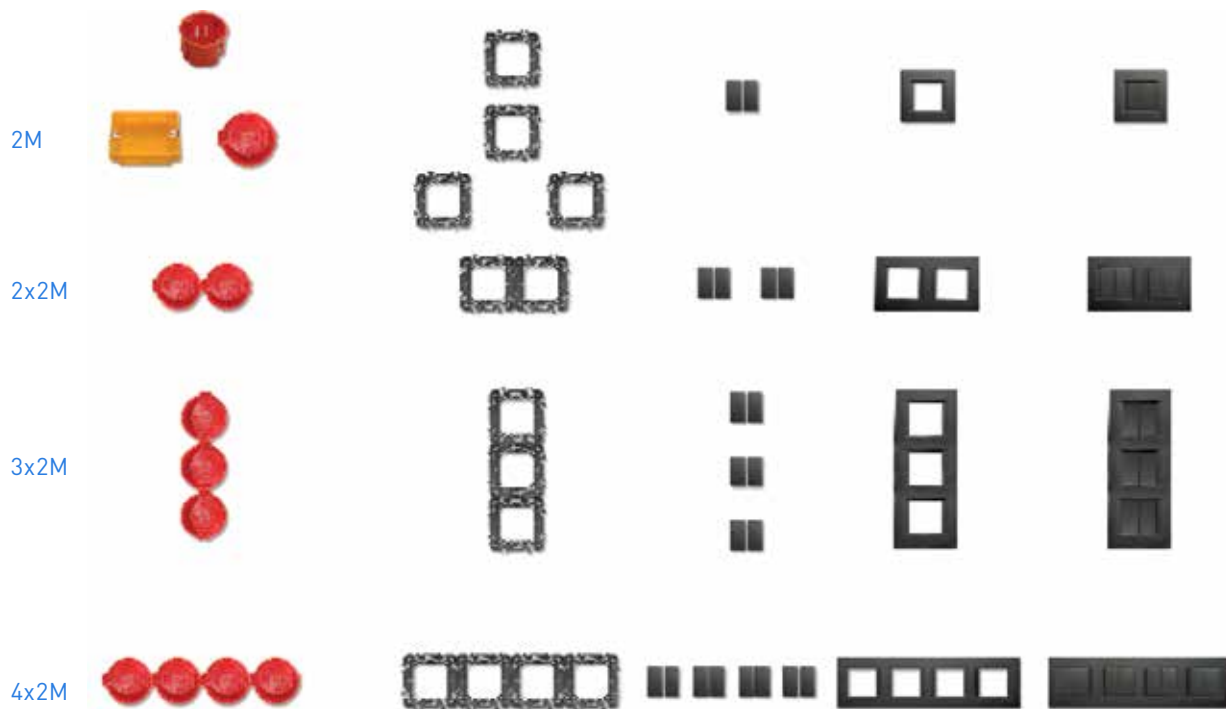

Panasonic

TECHNICAL INFORMATION KNX Standard Push Button

Using Mechanism and Button Cover



**KNX SWITCH BAU
(BUS ACCESS UNIT)**



WRKT66015**
KNX STANDARD PUSH BUTTON
MULTI COLOR+TEMP 1 GANG



KNX 1 GANG SWITCH COVER



**KNX SWITCH BAU
(BUS ACCESS UNIT)**



WRKT66025**
KNX STANDARD PUSH BUTTON
MULTI COLOR+TEMP 2 GANG



KNX 2 GANG SWITCH COVER



**KNX SWITCH BAU
(BUS ACCESS UNIT)**



WRKT66035**
KNX STANDARD PUSH BUTTON
MULTI COLOR+TEMP 3 GANG



KNX 3 GANG SWITCH COVER

COLOR CODE	
XX	EXPLANATION
WH	WHITE
MW	METALLIC WHITE
BG	BEIGE
DR	DORE
AN	ANTHRACITE
DG	DARK GRAY
BL	BLACK

SWITCH

Button Color Alternatives



Frame

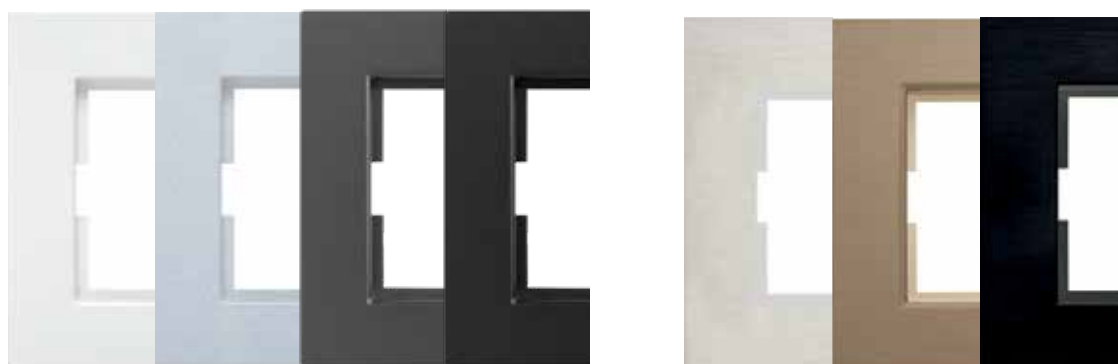

White Silver Dark Gray Black

Aluminum Silver Aluminum Bronze Aluminum Black

For frame options, please contact with the relevant sales point.

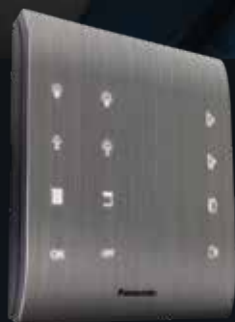

*Experience the Future of
Smart Control with **Multis***

***Multis** is Now Available in Black*

SWITCHES

KNX Multi Functional Switch

KNX Multi Functional Switch (LCD Display)



KNX Multi Functional Switch (No Display)



■ MAIN FEATURES

- Configurable up to 4 Gang with/without LCD
- 12 capacitive touch buttons with sound feedback
- Customized icon label stickers for touch buttons
- Single and rocker button and LEDs options
- Activating standby mode according to presence information with proximity sensor
- Adjusting backlights according to ambient light with brightness sensor
- Controlling thermostat functions with temperature and humidity sensor
- Weekly thermostat program with internal timer
- Scene actuator functions
- Energy saving functions

■ PRODUCT CODES

Product	Product codes
KNX Multi Functional Switch 4 Gang MS104 FA	WRKT62045FA
KNX Multi Functional Switch 4 Gang MS104-D FA	WRKT62145FA
KNX Multi Functional Switch 4 Gang Black MS104-D FB	WRKT62145FB
KNX Multi Functional Switch 4 Gang Black MS104 FB	WRKT62045FB

■ TECHNICAL DATA

Supply voltage	21 to 32V DC via KNX Bus
Operating temperature	-5 °C... + 45°C
Type of protection	IP 20 to EN60529
Safety class	III to IEC 60664-1
Cable lenght for ext. inputs	Max. 3 m
Temperature measuring	0% to 45 °C
Relative humidity	0% to 100%
Current consumption	With LCD 30mA Without LCD 10mA

■ DIMENSIONS

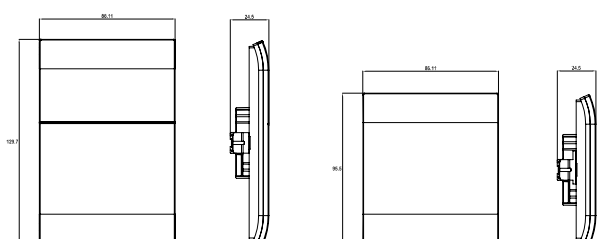



POWER SUPPLY & INTERFACE



Power Supply



Interface

Panasonic

KNX POWER SUPPLY PS132 - 320mA / PS164 - 640mA



MAIN FEATURES

- Reliable and safe power connection with line over voltage protection for the AC mains input.
- Ultimate reliability with built-in Overload and Short Circuit Protection on the outputs.
- Compact DIN4 Size, which redefines space efficiency with 4 modules at only 18 mm, offers powerful protection without compromising form.
- Stay informed at a glance with LED Indication, seamlessly signaling the status, whether it's a smooth operation or an alert for overload.
- Enjoy versatility with an Additional Unchoked Auxiliary Output, providing an extra layer of connectivity for your diverse needs
- Trust in quality with VDE-Certified assurance, ensuring our product meets the highest standards for safety and performance.

PRODUCT CODES

Product	Product codes
KNX POWER SUPPLY - PS132 - 320mA	WRKT20305NC
KNX POWER SUPPLY - PS164 - 640mA	WRKT20315NC

DIMENSIONS

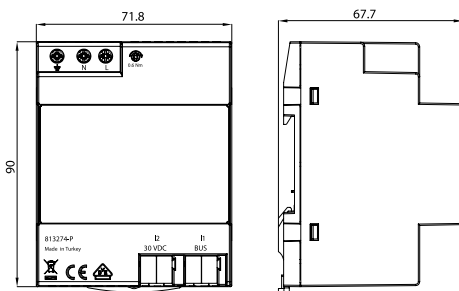

CONNECTORS AND LED DESCRIPTION

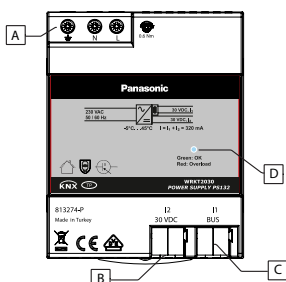

- A. AC Supply voltage terminals
 B. 30 VDC output connector
 C. BUS (KNX) TP output connector
 D. Status LED
- Status LED States:
 Green: BUS & 30 VDC are OK.
 Red:
- For 320 mA IOUT > 500 mA (Overload)
 - For 640 mA IOUT > 900 mA (Overload)

TECHNICAL DATA

Power input	
Mains voltage	230 VAC @50/60Hz
Leakage loss (open-circuited)	0.85W
Leakage loss (normal)	for 320 mA: 3.5 W, for 640 mA: 4.9W
Power consumption (normal)	for 320 mA: 13.9 W, for 640 mA: 25.6 W
Power consumpt.(max., overload)	for 320 mA: 20.4W @500mA for 640 mA: 35.3W @900mA
Housing	
Dimensions (HxWxD)	90 x 71.8 x 65.8 mm
Mounting (IEC60715)	35 mm top-hat rail (TH35)
Width in space units	4 modules at 18 mm
AC supply input connection	Single wire: 1.5...4mm ² or 2x1.5...2x2.5mm ² Stranded wire without ferrule: 0.75...4mm ² Stranded wire with ferrule: 0.5...2.5mm ² max. torque: 0.6Nm
KNX bus connection	KNX TP connector (red/black)
AUX output connection	KNX TP connector (white/yellow)
Weight	217.3gr
Environmental conditions	
Operating temperature	5...+45 °C
Storage temperature	-10...+55 °C
Ambient humidity	5...93 % (non-condensing)
Power output	
BUS output voltage	28...31 V DC (SELV)
30 VDC output voltage	28...31 V DC (SELV)
Rated current (BUS + 30 VDC)	320 mA, 640 mA
Mains failure bridging time	> 100 ms
Short circuit current (BUS + 30 VDC)	for 320 mA: 700 mA for 640 mA: 1300 mA
Electrical safety	
Pollution degree (IEC60664)	2
Protection type (IEC60529)	IP20
Overvoltage category (IEC60664)	III
Certification (ISO/IEC14543-3)	VDE-certified
CE Marking	
EU Directives	EMC and LVD guidelines

KNX AREA / LINE COUPLER TP



MAIN FEATURES

- Connecting two TP lines as main line and sub line and the electrical separation these lines from each other
- According to the address and parameters assigned to the device; use as field, line coupler or line repeater (without filtering)
- Configured button to temporarily deactivate filtering for commissioning and troubleshooting
- Indicated operation and filtering statuses by LEDs

PRODUCT CODES

Product	Product codes
KNX Area / Line Coupler TP	WRKT21015NC

DIMENSIONS

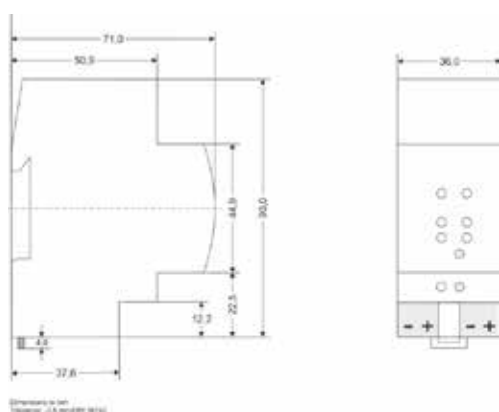

CONNECTION

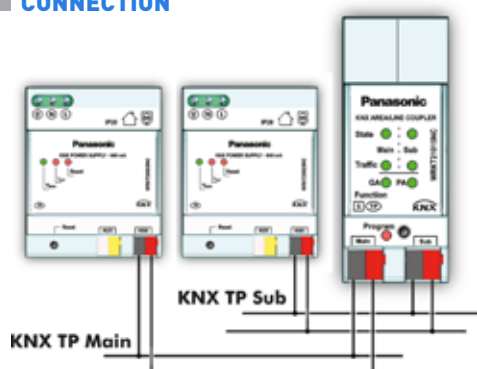

TECHNICAL DATA

Power input	
Power supply	21 ... 30 V DC SELV
Current consumption	< 10 mA (from main line)
Housing	
Dimensions (HxWxD)	90 x 36 x 71 mm
Mounting (IEC60715)	35 mm top-hat rail (TH35)
Width in space units	2 modules at 18 mm
KNX bus connections	KNX connector (red/black) for KNX TP main line & subline
Weight	62 g
Environmental conditions	
Operating temperature	-5...45 °C
Storage temperature	-20...60 °C
Ambient humidity	5...93 % (non-condensing)
Electrical safety	
Pollution degree (IEC60664)	2
Protection type (IEC60529)	IP20
Protection class (IEC61140)	III
Overvoltage category (IEC60664)	III
Approbation (ISO/IEC14543-3)	KNX-certified

KNX USB GATEWAY TP



■ MAIN FEATURES

- Connecting PCs to the system via USB
- Provides a bi-directional connection to the KNX TP bus system
- No external power supply is necessary

■ PRODUCT CODES

Product	Product codes
KNX USB Gateway TP	WRKT25325NC

■ DIMENSIONS

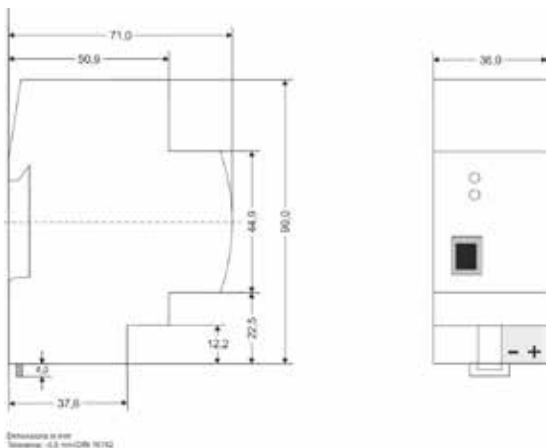

■ CONNECTION

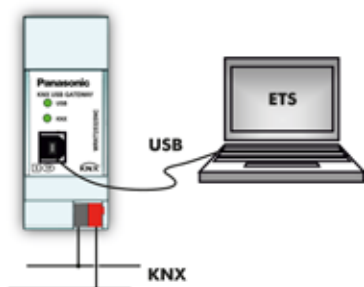

■ TECHNICAL DATA

Power input	
Power supply	21...30 V DC SELV USB, 5 V DC
Current consumption	< 5 mA (KNX TP) < 20 mA (USB)
Housing	
Dimensions (HxWxD)	90 x 36 x 71 mm
Mounting (IEC60715)	35 mm top-hat rail (TH35)
Width in space units	2 modules at 18 mm
KNX bus connection	KNX connector (red/black)
IP connector	USB2.0 (Type B, female)
Weight	62 g
Environmental conditions	
Operating temperature	-5...45 °C
Storage temperature	-20...60 °C
Ambient humidity	5...93 % (non-condensing)
Electrical safety	
Pollution degree (IEC60664)	2
Protection type (IEC60529)	IP20
Protection class (IEC61140)	III
Overvoltage category (IEC60664)	III
Approbation (ISO/IEC14543-3)	KNX-certified

KNX IP ROUTER TP



MAIN FEATURES

- Connecting KNX IP and KNX TP
- Integration KNX IP / Ethernet with TP Bus system
- Supporting KNXnet / IP routing and tunneling functions
- Indicated operation and filtering statuses by LEDs
- Connecting KNX IP devices by a standard RJ45 connector directly and also via Ethernet networks
- A rail-mounted device for installation in distribution boards on 35 mm DIN rails
- Integrated bootloader function for remote firmware updates via IP / Ethernet
- Temporary deactivation of filtering by a single button press (Eases commissioning because of short-time access to other lines.)
- No need for an additional power supply

PRODUCT CODES

Product	Product codes
KNX IP ROUTER TP	WRKT23315NC

DIMENSIONS

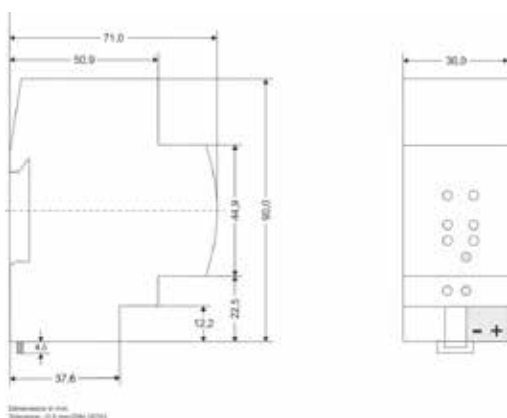

CONNECTION

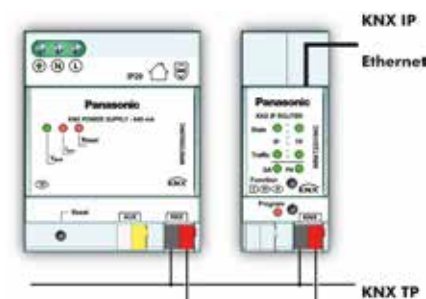

TECHNICAL DATA

Power input	
Power supply	21...30 V DC SELV
Current consumption	< 20 mA
Housing	
Dimensions (HxWxD)	90 x 36 x 71 mm
Mounting (IEC60715)	35 mm top-hat rail (TH35)
Width in space units	2 modules at 18 mm
KNX bus connection	KNX connector (red/black)
IP connector	Ethernet (RJ45, female)
Weight	68 g
Environmental conditions	
Operating temperature	-5...45 °C
Storage temperature	-20...60 °C
Ambient humidity	5...93 % (non-condensing)
Electrical safety	
Pollution degree (IEC60664)	2
Protection type (IEC60529)	IP20
Protection class (IEC61140)	III
Overvoltage category (IEC60664)	II
Approbation (ISO/IEC14543-3)	KNX-certified

KNX IP INTERFACE TP



MAIN FEATURES

- Providing an IP connection to KNX TP
- Suitability for connection of KNX IP devices, a PC with ETS and Ethernet networks
- Support KNXnet / IP tunneling function and set up to four physical addresses
- Indicated operation statuses by LEDs
- Connecting KNX IP devices by a standard RJ45 connector directly and also via Ethernet networks
- A rail-mounted device for installation in distribution boards on 35 mm DIN rails
- Integrated bootloader function for remote firmware updates via IP / Ethernet
- No need for an additional power supply

PRODUCT CODES

Product	Product codes
KNX IP INTERFACE TP	WRKT23305NC

DIMENSIONS

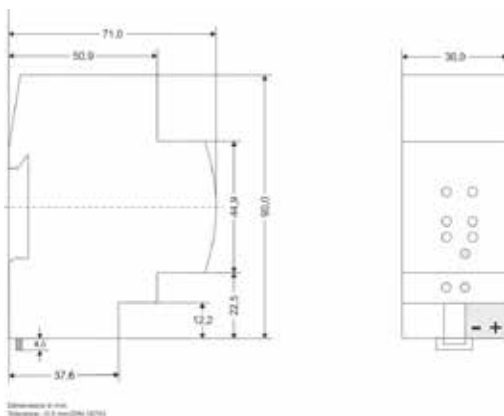

CONNECTION

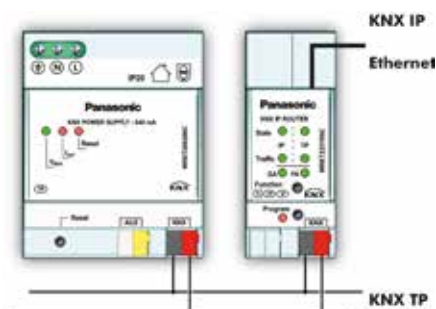

TECHNICAL DATA

Power input	
Power supply	21...30 V DC SELV
Current consumption	< 20 mA
Housing	
Dimensions (HxWxD)	90 x 36 x 71 mm
Mounting (IEC60715)	35 mm top-hat rail (TH35)
Width in space units	2 modules at 18 mm
KNX bus connection	KNX connector (red/black)
IP connector	Ethernet (RJ45, female)
Weight	68 g
Environmental conditions	
Operating temperature	-5...45 °C
Storage temperature	-20...60 °C
Ambient humidity	5...93 % (non-condensing)
Electrical safety	
Pollution degree (IEC60664)	2
Protection type (IEC60529)	IP20
Protection class (IEC61140)	III
Overvoltage category (IEC60664)	II
Approval (ISO/IEC14543-3)	KNX-certified

KNX DALI GATEWAY DL101/ DL102



MAIN FEATURES

- For each DALI channel, 64 ballasts, 16 groups, 16 scenarios and broadcast control
- For each DALI ballast and group, staircase, night, panic and burn-in mode control over KNX
- Faults monitoring of DALI ballasts via KNX
- Automatic addressing of ballasts in DALI bus
- Manual control and monitoring of ballasts on the DALI bus via the user interface
- Feature of DALI power supply
- Software update over Ethernet

PRODUCT CODES

Product	Product codes
KNX DALI GATEWAY DL101 (1 Channel)	WRKT22245NC
KNX DALI GATEWAY DL102 (2 Channels)	WRKT22255NC

DIMENSIONS

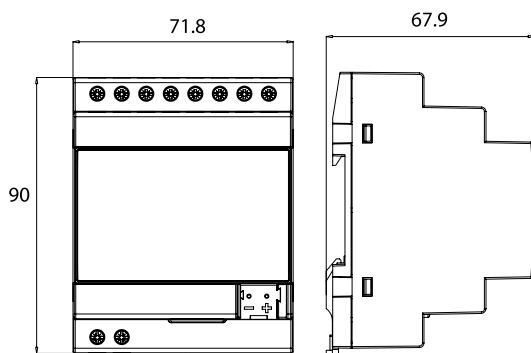

CONNECTION

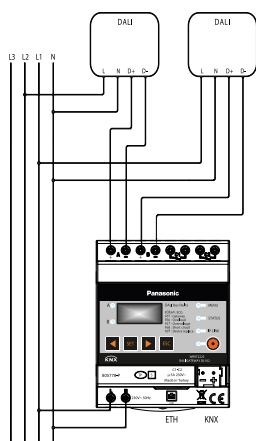

TECHNICAL DATA

SUPPLY VOLTAGE	
Voltage range	230 V AC, 50/60 Hz
Power consumption total via mains	Max. 8W (at 230 V AC and max. load) (for 1 ch.) Max. 12W (at 230 V AC and max. load) (for 2 ch.)
DALI	
Number of outputs	1 channel 2 channel
Number of DALI devices	Maximum 64 ballast per output
Protection	Short circuit, Overload, Over-voltage (230VAC)
DALI voltage	
No-load voltage	18 V DC
Maximum supply current	250 mA
Guaranteed supply current	230 mA
	18 V DC 2x250 mA 2x190 mA
	The DALI control voltage is a functional extra-low voltage (FELV).
DALI cable lengths (for copper wire)	- 2.5 mm ² max. 300 m - 1.5 mm ² max. 300 m - 1.0 mm ² max. 224 m - 0.75 mm ² max. 168 m - 0.5 mm ² max. 112 m
DALI transmission rate	1200 bit / s
KNX	
KNX voltage	DC 21 ... 32 V SELV
KNX current consumption	<5 mA
KNX interface	TP1
Configuration mode	S-Mode
IP	
Connections Speed	10/100 Mbits
RELAY OUTPUT	
Output Contact 1	1 N/O, 2A-277V AC Resistive, 2A 30V DC
Output Contact 2	1 N/O, 2A-277V AC Resistive, 2A 30V DC
BUTTONS AND DISPLAY	
Control buttons	<, SET, >, ESC (Total 4 button)
Display and LED elements	MENU, STATUS 1/2, IP LINK/TRAFFIC, KNX PROG., A, B (only 2 channels) - Total 6 LED indicators 3 Digit 7-Segment LED Display
ENVIRONMENTAL CONDITIONS	
Protection degree (IEC60529)	IP20
Protection class (IEC61140)	II
Isolation category	Overvoltage category III (IEC60664) Pollution degree 2 (IEC60664)
Temperature range	Operation -5...+45 °C Storage -10...+55 °C Transport -25...+70 °C
Humidity	5...93% (non-condensing)
MECHANICAL DESIGN	
Dimensions (HxWxD)	90mmx71,8mmx65,8mm
Mounting (IEC60715)	35 mm top-hat rail (TH35)
Mounting width	DIN rail 72mm (4 modules)
KNX bus connection	KNX connector (243-211 Wago)
IP Connector	Ethernet (RJ45, female)
Connection type (Power/Relay/DALI)	Screw terminal Single wire: 1,5mm ² ...4mm ² or 2x1,5mm ² ...2x2,5mm ² Stranded wire without ferrule: 0,75mm ² ...4mm ² Stranded wire without ferrule: 0,5mm ² ...2,5mm ²
Weight	0.22 kg

Panasonic

KNX INPUT MODULE 20 GANG DRY-CONTACT IO100 / 20/8 GANG DRY-CONTACT/230V IO101



MAIN FEATURES

- LEDs on the front of the device to indicate the signal status of the inputs.
- Manual operation buttons to simulate and override the status of the inputs
- 20 x Dry-contact inputs
- 8 x 10-230V AC/DC inputs (Only in IO101)
- 4 x virtual inputs
- Vout port can be used to supply an external device with 5V up to 75 mA.
- Switching and dimming lighting with one or two inputs
- Controlling blinds and shutters with one or two inputs
- Calling and saving scenes
- Sending up to 3 values of any type (percentage - HVAC mode - temperature - 1, 2 or 4-byte values etc.)
- Distinction between short and long presses - single and double presses of a connected push button
- Inputs signals can be monitored, delayed, locked, sent to the bus and simulated via an object
- 32 auxiliary functions. The type of each function can be selected from 14 different types (Sequencer, Counter, Scene Actuator, Filter, Converter, Logic Gate, Presence detector controller, Staircase controller...). The inputs of some of these functions can be assigned to be internal inputs or external objects

PRODUCT CODES

Product	Product codes
KNX INPUT MODULE 20 GANG DRY-CONTACT IO100	WRKT4000E5NC
KNX INPUT MODULE 20/8 GANG DRY-CONTACT/230V IO101	WRKT4001E5NC

DIMENSIONS

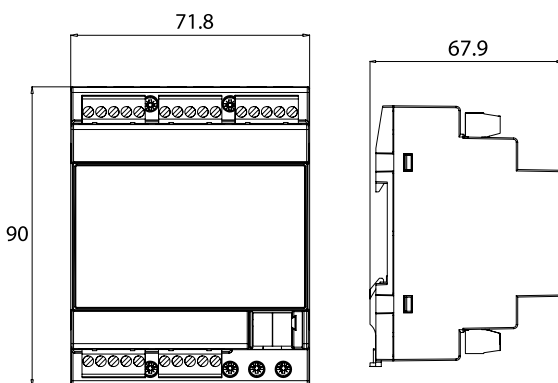

TECHNICAL DATA

Power	
Operating voltage	DC 21-32 V (from KNX bus)
Maximum current consumption - Vout disabled	20mA from KNX bus
Maximum current consumption - Vout enabled	40mA from KNX Bus
Environmental conditions	
Ambient temperature	-5 C ... +45 C
Storage temperature	-10 C ... +55 C
Ambient humidity	5...93% (non-condensing)
Housing	
Dimensions (HxWxD)	90mmx71.8mmx67.9mm
Mounting (IEC60715)	35 mm top-hat rail (TH35)
Mounting width	DIN rail 72mm (4 modules)
KNX bus connection	KNX connector (243-211 Wago)
Weight	For IO100: 136,75 gr For IO101: 209,45 gr
10-230V Input connector (only IO 101)	16x Screw Terminals
Dry Contact Input connector	5x 5pin 3.81mm Pluggable Terminals
Electrical safety	
Protection type (IEC60529)	IP 20
Pollution degree (IEC60664)	2
Protection class (IEC61140)	II
Overvoltage category (IEC60664)	III
Standards	
EMC, LVD, KNX	TS EN 50428, TS EN 60669-2-1, EN 50090

Dry contact inputs	
Scanning voltage	3.3V
Scanning current	10uA
Scanning current at switch on	400uA
Maximum cable length	100 meters
Minimum cable cross section	1mm ²

Vout	
Output voltage	5V ± 10%
Maximum current	75mA
Maximum cable length	100 meters
Minimum cable cross section	1mm ²

10-230V AC / DC inputs	
Permissible voltage range	10-230V AC/DC
Maximum input current	1mA
Signal level for 0 signal	0...3 V AC/DC
Signal level for 1 signal	8...230 V AC/DC
Maximum cable length	100 meters
Minimum cable cross section	1mm ²

CONNECTION

• Dry Contacts Connection

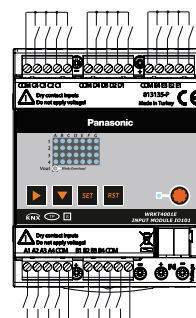

• 10-230V AC Connection

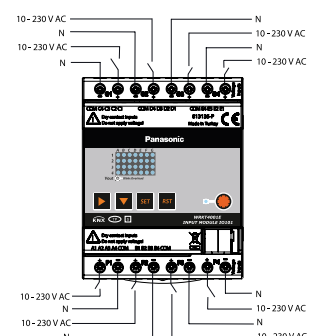

KNX INPUT/OUTPUT MODULE



MAIN FEATURES

Panasonic KNX I/O Module is an input and output device designed to full the automation requirements of residential and commercial KNX projects. It comes with KNX Data Secure feature which assures secure data communication on twisted pair bus line for the compatible devices. Panasonic KNX I/O Module can be used to connect conventional switches and binary sensors (e.g. presence detector, card holder etc.) to the KNX bus. Feedback LEDs in conventional switches can also be connected, thanks to its con-gurable inputs which can be used to drive feedback LEDs as well. Panasonic KNX I/O Module has competent control features such as Lighting, Heating, Shutter and Fan Coil. The current status of the input and output signals can be visualized on the device with its status LEDs. Signals can be manually overridden using the device's manual control button. Many complex con-gurations and various scenarios can be realized, thanks to the powerful auxiliary functions (i.e. logic, converter and sequence functions, etc.).

- KNX Data Security
- Manual Control
- Switching (Lighting / Heating)
- Shutter / Blind Control (AC / DC)
- Fan Coil (2 pipe / 4 pipe) Dry Contact Inputs (Switch-Sensor, Push Button, Card Holder, Feedback LED)
- Wide Range Voltage Inputs (10-230V)
- Auxiliary Functions (Sequencer, Counter, Scene Actuator, Filter, Converter, Logic Gate, Presence Detector Controller, Staircase Controller)

PRODUCT CODES

Product	Product codes
KNX Input/Output Module	WRKT4200J5NC

CONNECTION

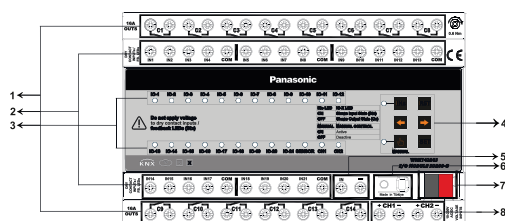

1. 16-A Output
2. Dry Contact Inputs
3. Status LEDs
4. Manual Operation Buttons
5. Sensor Input
6. KNX Programming Button and LED
7. KNX Bus Terminal
8. 10-230V AC/DC Inputs

TECHNICAL DATA

Power	
Operating voltage	DC 21-32 V (from KNX bus)
Current consumption	Max. 40mA
Environmental Conditions	
Ambient temperature	-5 C ...+45 C
Storage temperature	-10 C ... +55 C
Ambient humidity	5...93% (non-condensing)
Housing	
Dimensions (HxWxD)	90mmx143.8mmx65.8mm
Mounting (IEC60715)	35 mm top-hat rail (TH35)
Mounting width	DIN rail 144mm (8 modules)
KNX bus connection	KNX connector (243-211 Wago)
Input/Output connector	60x Screw Terminals
Weight	533,35 g
Input & Output	
Outputs	14ch 16A latching type relay
Inputs	21Ch dry contact input (Con gurable as feedback LED) 2 Ch voltage input (10-230V AC/DC) 1Ch sensor input
Electrical safety	
Protection type (IEC60529)	IP 20
Pollution degree (IEC60664)	2
Protection class (IEC61140)	II
Overvoltage category (IEC60664)	III
CE Marking / Standard	
EMC	EN 60669-2-1
LVD	EN 60669-2-1
KNX	EN 50090

DIMENSIONS

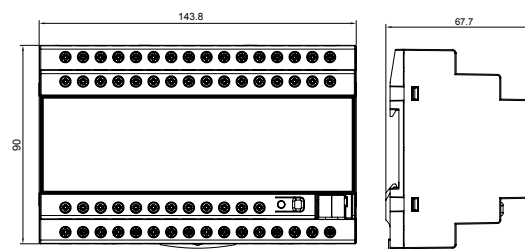

Panasonic

POWER SUPPLY & INTERFACE

Binary Inputs for flush-mounted sockets 2/4/6 way

KNX Binary Inputs for flush-mounted sockets 2/4/6 way

KNX Binary Input 2-Way

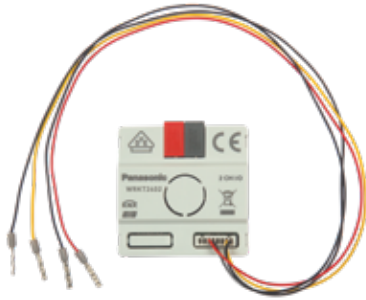

KNX Binary Input 4-Way

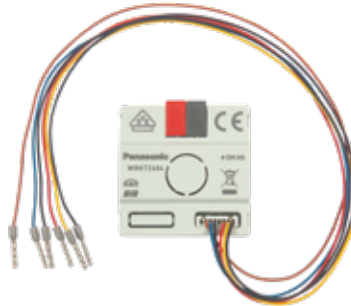

KNX Binary Input 6-Way

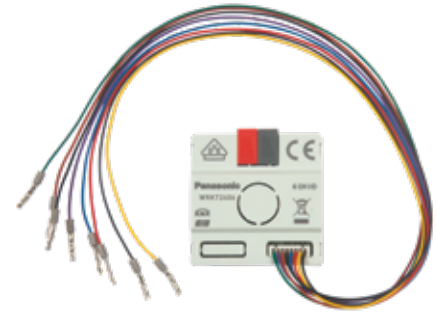

■ MAIN FEATURES

- Binary input modules with 2, 4 or 6 inputs for floating switch/push button contacts
- Can be installed in combination with conventional push buttons/switches in flush-mounted sockets
- Inputs can be reconfigured to outputs: binary input: potential-free contact/binary output: 1mA (low current) (LED 1mA types)
- Adjustable response to restoration of the bus supply

■ INPUT FUNCTIONS

The following functions can be configured:

- Switch / push button input
- Dimmer control
- Control of blinds
- Value
- Up to 4 Command LED (With BI 6-way, only C1...C4)

■ TECHNICAL DATA

General		Inputs	
Power supply	Bus voltage	Quantity	2 Way: 2 outputs 4 Way: 4 outputs 6 Way: 4 outputs
Ambient temperature	-5 °C... + 45°C	Use	Low current LEDs without series resistor
Current draw from bus voltage	Max 10mA	Output current	Maximum 1mA / output
Bus connection	Bus terminal		
Type of protection	IP 20 to EN 60529		
Degree of pollution	2 to IEC 60664-1		
Protection class	Class III to IEC 61140		
Overvoltage class	Class III to IEC 60664-1		
Dimensions	LxWxH 37x37x12 (mm)		

■ PRODUCT CODES

Product	Product codes
KNX Binary Input 2-Way	WRKT24025NC
KNX Binary Input 4-Way	WRKT24045NC
KNX Binary Input 6-Way	WRKT24065NC

■ DIMENSIONS

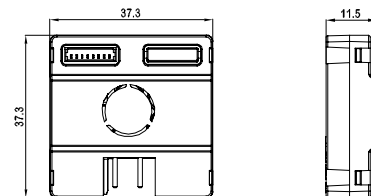

■ CONNECTION

KNX Binary Input 2-Way



KNX Binary Input 4-Way

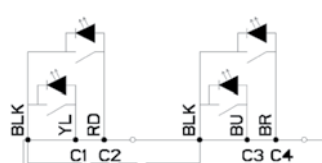

KNX Binary Input 6-Way

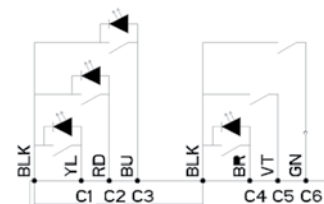

KNX IR INTERFACE IR 100



Introducing the KNX IR Interface – your intelligent assistant for controlling devices with remote controls. It reads and sends signals from various brands, making it perfect for homes and offices.

Manage everything from your TV to your air conditioner, DVD player, and more devices that have an IR receiver. The KNX IR Interface even lets you control lights, blinds, and thermostats using your remote.

No need for extra power – it gets its power from the KNX bus. Simplify your life with the easy and efficient KNX IR Interface.

■ MAIN FEATURES

- Small size 37 x 37 x 11.7 mm; can fit in standard electrical box
- Ability to use 3 ports as transmitter and 1 port as transmitter or receiver of the device
- Ability to use 100 channels to transfer commands from KNX to IR or from IR to KNX
- Ability to send an IR code repeatedly with configurable time delays from KNX to IR channels
- Use of IR to KNX channels for control lights, blinds and thermostats and call scenes
- Ability to send multiple IR codes sequentially with 16 macros
- Control of 4 AC split units with by using KNX commands with 4 AC modules
- Use of logic gate, sequencer / counter, converter, scene actuator or send after reset function with 8 auxiliary functions
- Teaching IR codes and loading AC configuration with a Device Configuration App (DCA) in ETS
- Teaching IR code to up to 250 devices

■ TECHNICAL DATA

Supply voltage	21 ... 32 V DC via KNX Bus
Operating temperature	-5°C ... +45°C
Type of protection	IP 20 to EN60529
Safety class	III to IEC 60664-1
IR transmitter maximum transmitting distance (*)	5.5m
IR transmitter transmitting angle (*)	40°

■ PRODUCT CODES

Product	Product codes
KNX IR INTERFACE IR100 [Total]	WRKT26115NC
KNX IR TRANSMITTER	WRKT26401NC
KNX IR RECEIVER	WRKT26411NC

■ DIMENSIONS

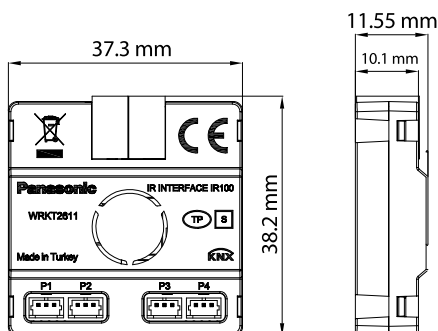

■ CONNECTION

1. Directly to the IR receiver of the controlled device
2. Near the controlled device or on the opposite wall

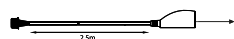
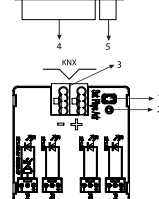
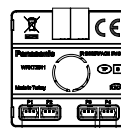
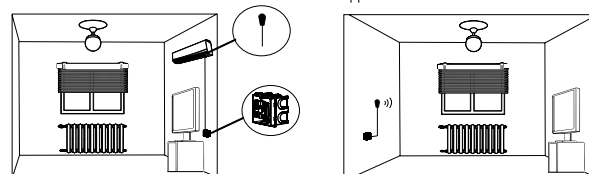

- 1- KNX programming button
- 2- KNX programming LED
- 3- KNX connector
- 4- IR transmitter ports
- 5- IR receiver/transmitter port (can be selected by ETS)
- 6- IR receiver
- 7- IR transmitter

Panasonic



ACTUATOR

Actuator



ACTUATOR Mix Actuator (Switching/Blind/Fancoil/Heating/Logic)

KNX SECURE MIX ACTUATOR 8CH MX308-16A-S



KNX SECURE MIX ACTUATOR 12CH MX312-16A-S

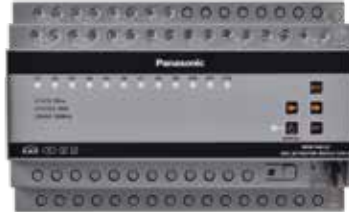

KNX SECURE MIX ACTUATOR 16CH MX316-16A-S



KNX SECURE MIX ACTUATOR 20CH MX320-16A-S



KNX SECURE MIX ACTUATOR 24CH MX324-16A-S



■ MAIN FEATURES

- Compact & Standard Sizes: Saves space in the panel with same size options for all channels.
- Better Inrush Current Capacity: Better inrush current capacity for more stable operation.
- Powered by KNX Bus: No external power supply needed, simplifying the installation.
- KNX Data Security: Provides secure communication over KNX bus lines with KNX Secure functionality.
- Manual Control: Local manual override for quick system adjustments & diagnostic.
- Lighting & Heating Control: Effortless switching of connected lighting and heating systems.
- Shutter & Blind Control (AC/DC): Supports automated control of motorized shutters and blinds.
- Fan Coil Management: Controls 2-pipe and 4-pipe fan coil systems for effective HVAC operation.
- Auxiliary Functions: Includes sequencer, scene actuator, logic gates, and more for advanced automation.

ACTUATOR

KNX Switching/Blind Actuators

TECHNICAL DATA

Power	
Operating voltage	DC 21-32 V (from KNX bus)
Current Consumption	Max. 40mA
Environmental Conditions	
Ambient temperature	-5 °C ... +45 °C
Storage temperature	-10 °C ... +55 °C
Ambient humidity	5...93% (non-condensing)
Housing	
Dimension (HxWxD)	90mmx143,8mmx65,8mm
Mounting (IEC60715)	35mm top-hat rail (TH35)
Mounting width	DIN rail 144mm (8 modules)
KNX bus connection	KNX connector (243-211 Wago)
Connection type	Screw terminal Single wire: 1,5mm ² -4mm ² or 2x1,5mm ² -2x2,5mm ² Stranded wire without ferrule: 0,75mm ² -4mm ² Stranded wire with ferrule: 0,5mm ² -2,5mm ²
Weight	8 Channels - 420gr 12 Channels - 495gr 16 Channels - 570gr 20 Channels - 645gr 24 Channels - 720gr
Current Load Rating Per Device	
WRKT4808J-	Sum of C1. . . C8 maximum 80A
WRKT4812J-	Sum of C1. . . C12 max mum 120A
WRKT4816J-	Sum of C1. . . C16 max mum 160A
WRKT4820J-	Sum of C1. . . C20 max mum 200A
WRKT4824J-	Sum of C1. . . C24 max mum 240A
Overall load current rating of neighbouring outputs	Max 20A Σ max. 20 A Σ max. 20 A Σ max. 20 A { C1 C2 C3 ... Cn }
Output (Rated Values)	
24x16A (NO) relay contact	Potential-free closing contacts, μ contact 230VAC 50/60Hz 10AX 250VAC 50/60Hz 16A AC1 (IEC 60947-4-1) Tungsten 2400W 230VAC LED 250W 230VAC max. 20ms (incand. lamps) 165A peak max. 200 μ s 800A peak
Electrical Safety	
Protection type (IEC60529)	IP20
Pollution degree (IEC60664)	2
Protection class (IEC61140)	II
Overvoltage category (IEC60664)	III
CE Marking / Standard	
EMC	EN 60669-2-1
LVD	EN 60669-2-1
KNX	EN 50090

PRODUCT CODES

Product		
KNX MIX ACTUATOR MX-308-16A-S		WRKT4808J5NC
KNX MIX ACTUATOR MX-312-16A-S		WRKT4812J5NC
KNX MIX ACTUATOR MX-316-16A-S		WRKT4816J5NC
KNX MIX ACTUATOR MX-320-16A-S		WRKT4820J5NC
KNX MIX ACTUATOR MX-324-16A-S		WRKT4824J5NC

PRODUCT COMPONENTS

1-16-A Outputs, 2- Status LEDs, 3- Manual Operation Buttons, 4- KNX Programming Button and LED, 5- KNX Bus Terminal

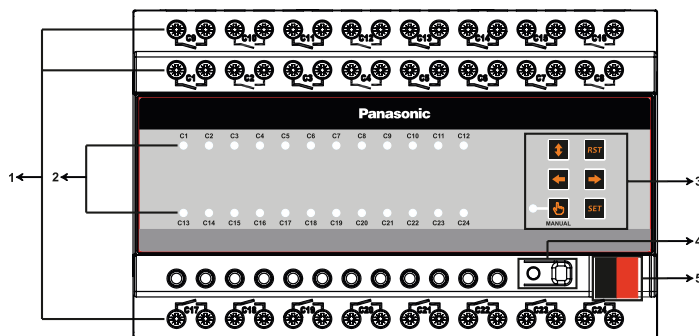

CONNECTION

Dry Contact Connection

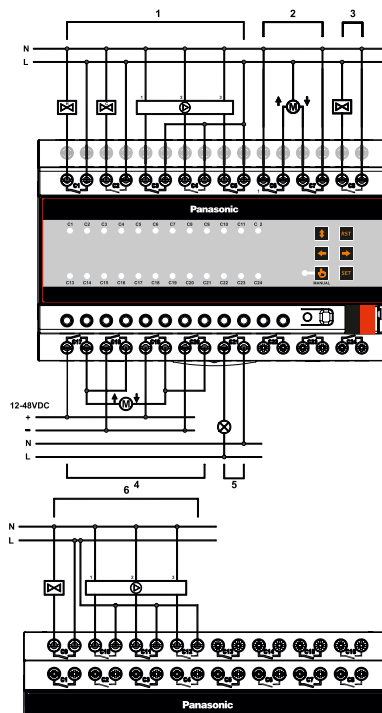

- 1- Fan Coil 4-pipe (Heating and Cooling)**
Outputs 1 to 5 are used for fan coil. Output 1 is used for heating valve, output 2 is used for cooling valve, outputs 3, 4 and 5 are used for fan levels.
- 2- Shutter/Blind AC**
Outputs 6 and 7 are used for shutter/blind AC connection.
- 3- Switching - Heating**
Output 8 is used for heating function.
- 4- Shutter/Blind DC**
Outputs 17 to 20 are used for shutter/blind DC connection.
- 5- Switching - Lighting**
Output 21 is used for switching - lighting function

- 1- Fan Coil 2-pipe (Heating or Cooling)**
Outputs 9 to 12 are used for fan coil. Output 9 is used for heating or cooling valve, outputs 10, 11 and 12 are used for fan levels.

DIMENSIONS

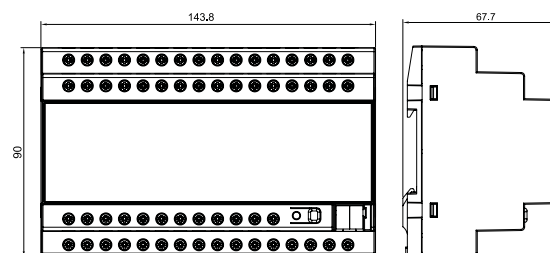

Panasonic

ACTUATOR Switching/Blind Actuators

KNX Switching/Blind Actuator 12/6 Gang



KNX Switching/Blind Actuator 8/4 Gang



KNX Switching/Blind Actuator 4/2 Gang



■ MAIN FEATURES

- On-site operation possible on the device (e.g. for installation testing), drives also possible without a bus voltage
- Status LED for each channel
- High switching capacity (16A with high-inrush current capacity)
- Different channel functions can be selected: Switching, On/Off Delay, Pulse, Staircase, Roller Shutter, Venetian Blind
- Possible integration of the channels into a maximum of 8 scenes
- Adjustable response to bus failure and restoration of the bus/mains power
- Central UP/DOWN object
- 3 safety objects and function
- Flexible reaction to safety telegrams: individually adjustable for each drive for start and end of the safety status
- Adjustable response to bus failure and restoration of the bus/mains power

■ CONNECTION

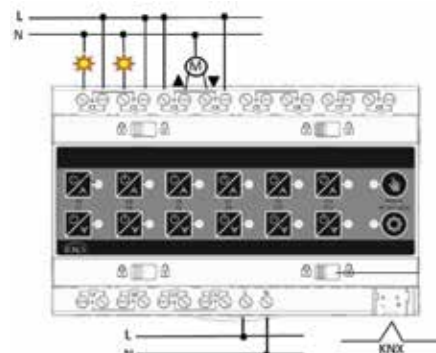

ACTUATOR

Switching/Blind Actuators

TECHNICAL DATA

KNX Medium	TP1
Mode of commissioning	S-Mode
KNX supply	21-32V DC
Mains supply	230V AC
Mains frequency	50/60Hz
Installation type	DIN rail
Mounting width	12/6 Channels - 144 mm (8 modules) 8/4 Channels - 144 mm (8 modules) 4/2 Channels - 72 mm (4 modules)
Ambient temperature	-5 °C ... +45 °C
Storage temperature	-25 °C ... +55 °C
Transportation temperature	-25 °C ... +70 °C
Connection	
KNX	KNX bus terminal
Mains and outputs	Screw terminals
Max. cable cross section	Single wire: 1.5 mm ² to 4 mm ² or 2 x 1.5 mm ² to 2x2.5 mm ² Stranded wire without ferrule: 0.75...4 mm ² Stranded wire with ferrule: 0.5 mm ² to 2.5 mm ²
Output contact type	NO , potential-free μ -contact, monostable
Switching Voltage AC	0-230V AC \pm 10%, 50/60Hz
Switching capacity at 230V AC	16A cos = 1 3A cos = 0.6

Loads per output	
Resistive load	3680W
Capacitive load	max. 21 μ F at 16A
Motors (shutter or fan)	600W
Max. inrush current	80A / 20 ms
Lamp loads	
Incandescent / Halogen load	2000W
230V halogen lamps	1800W
LV halogen lamps with Tronic transformers	800W
LV halogen lamps with inductive transformers	800VA
Fluorescent lamp load (conventional) parallel-corrected	2 x 58W (7 μ F), 3 x 36W (4,5 μ F), max. 120W (14 μ F)
Fluorescent lamp load (conventional) not corrected	14 x 58W, 20 x 36W, max. 1000VA
Fluorescent lamp (EB - Electronic ballast)	3 x 36W, 2 x 58W, max. 120W
Energy saving lamps	6 x 7W, 4 x 11W, 2 x 15W, 2 x 20W, 2 x 23W

PRODUCT CODES

Product	Product codes
KNX Switching/Blind Actuator 12/6 Gang	WRKT4512J5NC
KNX Switching/Blind Actuator 8/4 Gang	WRKT4508J5NC
KNX Switching/Blind Actuator 4/2 Gang	WRKT4504E5NC

DIMENSIONS

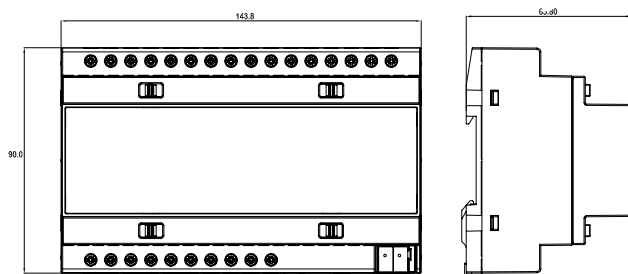

For only 12/6 and 8/4.

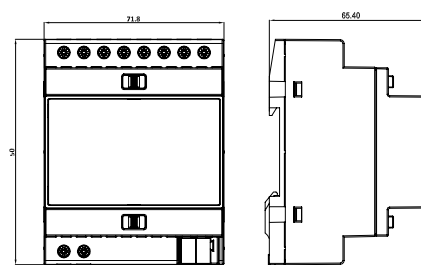

For only 4/2

Panasonic

ACTUATOR

Mix Actuators (Switching/Blind/Fancoil/Heating/Logic)

KNX MIX ACTUATOR MX208 - 16 A



KNX MIX ACTUATOR MX212 - 16 A



KNX MIX ACTUATOR MX216 - 16 A



KNX MIX ACTUATOR MX220 - 16 A



KNX MIX ACTUATOR MX224 - 16 A



Discover the KNX Mix Actuators – your affordable gateway to smart home control through the KNX bus. Streamline your space with versatile features:

■ MAIN FEATURES

Switching – Lighting: Effortlessly control lighting loads and electric consumers.

Switching – Heating: Optimize comfort by switching heating products or valves.

Shutter/Blind Control: Drive AC and DC motors for precise control over shutters and blinds.

Fan Coil Management: Tailor your environment with 2-pipe and 4-pipe system control, featuring up to 6 fan levels.

No Additional Power Supply: Powered directly via the KNX bus, eliminating the need for extra voltage supply.

Versatile Relay Options: Choose from versions with 8, 12, 16, 20, or 24 relays to match your automation needs.

Powerful Auxiliary Functions: Unlock creativity with 24 customizable functions, offering 14 different types from sequencers to presence detectors.

ACTUATOR

KNX Switching/Blind Actuators

TECHNICAL DATA

KNX	
KNX interface	TP1
Configuration mode	S-Mode
Bus voltage	21-32V DC
Power	
Operating voltage (Power supply)	DC 21 - 32 V (from KNX bus)
Current consumption (bus) / W/O switching	< 5mA
Current consumption (bus) / switching	< 12mA
Environmental conditions	
Ambient temperature	-5 °C ... +45 °C
Storage temperature	-10 °C ... +55 °C
Transportation temperature	-25 °C ... +70 °C
Ambient humidity	5...93% (non-condensing)
Housing (mechanical design)	
Installation type	DIN rail (IEC60715 35mm top-hat rail TH35)
Mounting width	8/12 Channels - 144mm (8 modules) 16/20/24 Channels- 252mm (14 modules)
Bus connection	KNX Bus terminal (243-211 Wago)
Connection type	Screw terminals
Max. Cable cross section for screw terminals	Single wire: 1.5 mm ² to 4 mm ² or 2 x 1.5 mm ² to 2x2.5 mm ² Stranded wire without ferrule: 0.75...4 mm ² Stranded wire with ferrule: 0.5 mm ² to 2.5 mm ²
Weight	8 Channels - 320gr 12 Channels - 370gr 16 Channels - 575gr 20 Channels - 625gr 24 Channels - 675gr
Electrical safety	
Protect on type (IEC60529)	IP 20
Pollut on degree (IEC60664)	2
Protect on class (IEC61140)	II
Overvoltage category (IEC60664)	III
Standards	
EMC - LVD	EN 60669-2-1, EN 50428
KNX	EN 50090
Current load rating per device	
WRKT4608J5NC	Sum of C1... C8 max mum 80A
WRKT4612J5NC	Sum of C1... C12 max mum 120A
WRKT4616Q5NC	Sum of C1... C16 max mum 160A
WRKT4620Q5NC	Sum of C1... C20 max mum 200A
WRKT4624Q5NC	Sum of C1... C24 max mum 240A
Overl load current rating of neighbouring outputs	Max 20A Σ max. 20 A Σ max. 20 A Σ max. 20 A { C1 C2 C3 } Ca

Output, (rated values)	
Switching Nominal Voltage	230 V AC 50/60 Hz
Switching Nominal Current (at 230 V AC)	16A (PF=1)
Output contact type	Potent al-free closing contacts, μ contact
DC Switching Capacity	5A 30V DC (Resistive)
Maximum connect on load per output	
Resistive	3680W
Inductive load (shutter)	600W
Incandescent / Halogen load	1200W
Max. inrush current	100A

PRODUCT CODES

Product	Product codes
KNX MIX ACTUATOR MX208	WRKT4708J5NC
KNX MIX ACTUATOR MX212	WRKT4712J5NC
KNX MIX ACTUATOR MX216	WRKT4716Q5NC
KNX MIX ACTUATOR MX220	WRKT4720Q5NC
KNX MIX ACTUATOR MX224	WRKT4724Q5NC

CONNECTION

- Fan Coil 4-pipe (Heating and Cooling): Outputs 1 to 5 are used for fan coil. Output 1 is used for heating valve, output 2 is used for cooling valve, outputs 3, 4 and 5 are used for fan levels.
 - Fan Coil 2-pipe (Heating or Cooling): Outputs 6 to 9 are used for fan coil. Output 6 is used for heating or cooling valve, outputs 7, 8 and 9 are used for fan levels.
 - Shutter/Blind DC: Outputs 16 to 19 are used for shutter/blind DC connection.
(!) To avoid short circuit, make sure that the ETS configuration of the channels which connected to the DC motor are done correctly.
(!) Fuse or short circuit protection should be used with DC power supply.
 - Switching - Lighting: Output 20 is used for switching - lighting function.
 - Shutter/Blind AC: Outputs 21 and 22 are used for shutter/blind AC connection.
 - Switching - Heating: Output 23 is used for heating function.
- NOTE: For the outputs, use circuit breakers for the respective rated current.

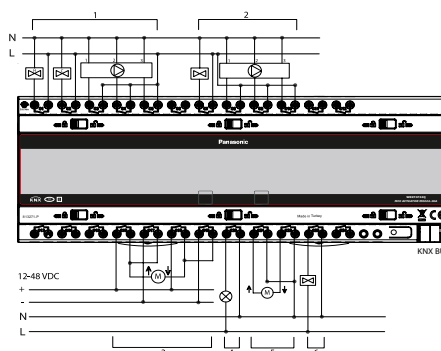

DIMENSIONS

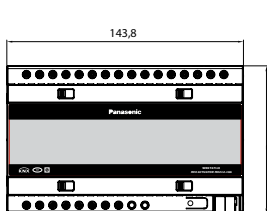

8 - 12 Outputs Device

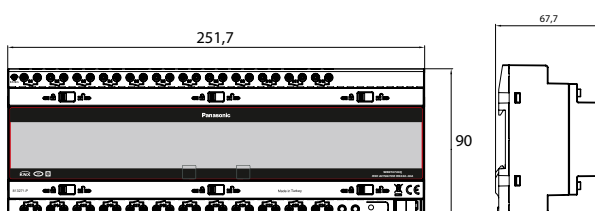

16 - 20 - 24 Outputs Device

Panasonic

KNX 1-10 V DIMMER CONTROL UNIT 4 GANG GV



The device depending on the product code varies.

■ MAIN FEATURES

- Switching the light
- Relative dimming
- Absolute dimming
- Status report
- Setting 15 scenes
- Staircase lighting function
- Bus recovery (or reset) function
- Preset value and modify preset value functions
- Switch/relative dimming via manual buttons

■ PRODUCT CODES

Product	Product codes
KNX 1-10 V DIMMER CONTROL UNIT 4 GANG GV	WRKT5144J5NC

■ DIMENSIONS

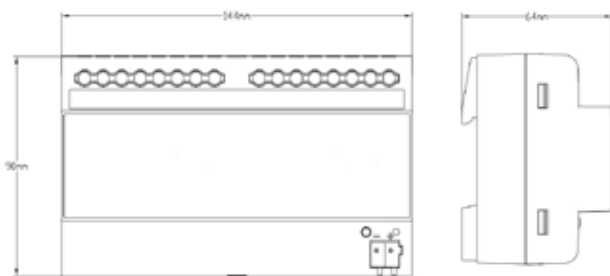

■ PRODUCT DESCRIPTION

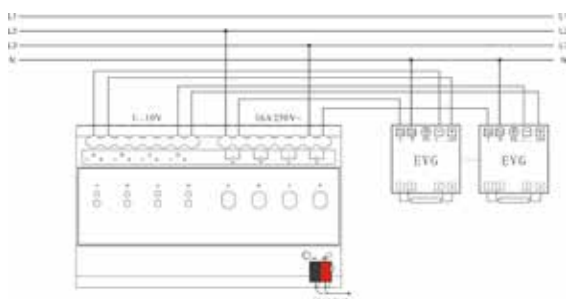

- 1- Mechanical manual operation
- 2- Programming button
- 3- Red LED for entering the physical address, green LED for application layer running normally
- 4- Bus connection terminal
- 5- Electronical manual button
- 6- LEDs of indicating output status for each channel, LED on meaning the channel has output, or else no output
- 7- Output, load terminals

■ TECHNICAL DATA

Power Supply	
Operating voltage	21~30V DC , via the EIB bus
Current consumption	<12mA
Power consumption	<360mW
Output	
Output voltage	1~10V DC(passive), max.100mA per output
Switch current	16A/250V AC
Connections	
EIB / KNX	Bus connection terminal (black/red)
Outputs	Using screw terminals
Operation and display	
Red LED and button	For assigning the physical address
Green LED flashing	For displaying the application layer running normally
Temperature	
Operation	-5°C ... + 45 °C
Storage	-25 °C ... + 55 °C
Transport	- 25 °C ... + 70 °C
Mounting	
Standard	35mm DIN rail installation

ACTUATOR

Dimming Actuators

KNX Dimming Actuator

KNX Dimming Actuator 2 Gang 300W DM102



KNX Dimming Actuator 4 Gang 250W DM104



MAIN FEATURES

- 2 channel and 4 channel versions
- Dimming range 0-100%
- For dimming incandescent lamps, low voltage and high voltage halogen lamps, Dimmable CFL and Dimmable LED Driver loads
- Device and KNX bus module can be swapped independently of each other.
- Removable KNX bus module enables devices to be changed without reprogramming.

- LED channel status indicator for each channel
- Manual operation on device (even without bus connection)
- Dimming output: 300W per channel for 2 channels version, 250W per channel for 4 channels version.
- Automatic load type detection (can be deactivated)
- For R, L and C load

TECHNICAL DATA

KNX Medium	TP1
Mode of commissioning	S-Mode
KNX supply	21-32V DC
Mains supply	230V AC
Mains frequency	50Hz
Installation type	DIN rail
Mounting width	4 Channels - 144 mm (8 modules) 2 Channels - 72 mm (4 modules)
Ambient temperature	-5°C...+45°C
Storage temperature	-25°C...+55°C
Transportation temperature	-25°C...+70°C
Connection	
KNX	KNX bus terminal
Mains and outputs	Screw terminals
Max. cable cross section	Single wire: 1.5 mm ² to 4 mm ² or 2 x 1.5 mm ² to 2x2.5 mm ² Stranded wire without ferrule: 0.75...4 mm ² Stranded wire with ferrule: 0.5 mm ² to 2.5 mm ²
Max Loads	DM102 (2 channels) DM104 (4 channels)
Incandesant & Halogen HV	300W (200W in inductive mode) 250W (200W in inductive mode)
Halogen LV (Ferromagnetic Trasformer)	300VA (Capacitive mode not allowed) 250VA (Capacitive mode not allowed)
Halogen LV (Electronic Trasformer)	300VA (Inductive mode not recommended) 250VA (Inductive mode not recommended)
Dimmable LED (Retrofit) & CFL	300VA (30VA in inductive mode, auto calibration mode not recommended) 250VA (30VA in inductive mode, auto calibration mode not recommended)

PRODUCT CODES

Product	Product codes
KNX Dimming Actuator 2 Gang 300W DM102	WRKT5512E5NC
KNX Dimming Actuator 4 Gang 250W DM104	WRKT5414J5NC

CONNECTION

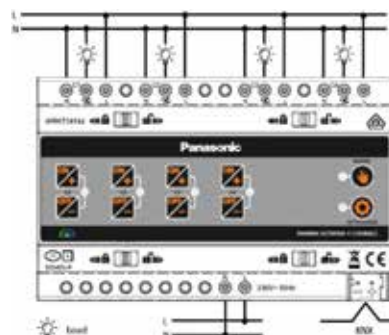

DIMENSIONS

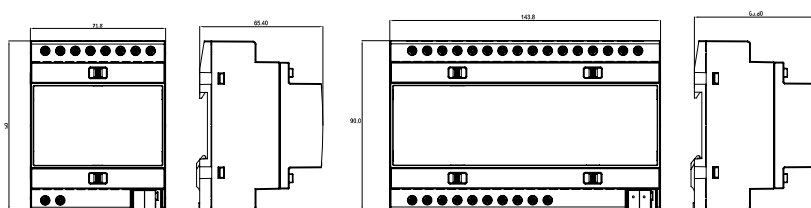

* The maximum load declaration is under ambient temperature 25°C, and maximum mains voltage 230V AC/ 50Hz. If ambient temperature is over 25°C, the maximum load should be reduced.



SENSOR & DETECTOR

Thermostat



SENSOR & DETECTOR

KNX Modular Thermostat



Enhance your comfort with our latest upgrade – introducing a stylish white screen design with smart and user-friendly settings for a contemporary and efficient solution.

■ MAIN FEATURES

- Individual room thermostat for controlling heating actuators and fan coil units
- Can be used as continuous or two point control
- Continuous PI control can be configured for heating and cooling
- Can support the operating modes as comfort, night/standby, frost/heat protection, presence and window status.
- Operation mode and temperature set value can be changed by user via buttons.
- Can be located into all frames of Thea Modular Series; Optima, Sistema and Ultima

■ TECHNICAL DATA

Programming mode	S Mode
Operating voltage	DC 21-32 V (from KNX bus)
Ambient temperature	-10°C ... +55°C
Storage temperature	-5°C ... +45°C
Maximum current consumption	Max 10 mA
KNX bus connection	KNX connector (243-211 Wago)

■ PRODUCT CODES

Product	Product codes
KNX Modular Thermostat White	WRKT33105WH
KNX Modular Thermostat Beige	WRKT33105BG
KNX Modular Thermostat Metallic White	WRKT33105MW
KNX Modular Thermostat Anthracite	WRKT33105AN
KNX Modular Thermostat Dark Gray	WRKT33105DG
KNX Modular Thermostat Dore	WRKT33105DR
KNX Modular Thermostat Black	WRKT33105BL

■ DIMENSIONS

Thermostat Module

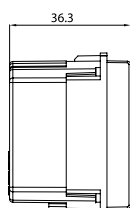
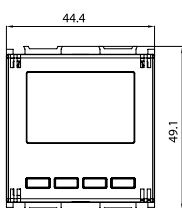

Mounting Frame

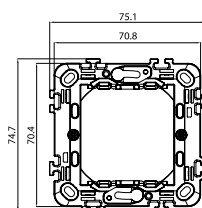

■ PRODUCT COMPONENTS

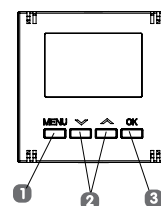

- 1) MENU: Settings
- 2) Up-Down Buttons: Changing
- 3) OK: Confirming selections

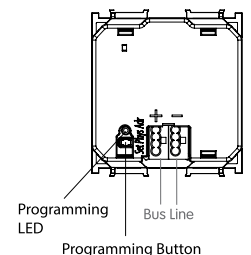

SENSOR & DETECTOR

KNX Modular Thermostat

■ COLOR ALTERNATIVES



Opaque White



Beige



Metallic White



Dore



Anthracite



Dark Gray



Black



KNX Standard Thermostat

■ COLOR ALTERNATIVES



White Silver Dark Gray Black



Aluminum Silver Aluminum Bronze Aluminum Black

SENSOR & DETECTOR

KNX Ceiling Type Presence Detector



Surface Mount Installation Box



■ MAIN FEATURES

- The PIR sensor on the product has a moving lens (mechanical adjustment) and a shade ring allow users to easily customize the coverage area and detection range
- RGB LED can be used to indicate movements or/and one of the measurements value
- Mixed light measurement suitable for fluorescent (FUPUESL), halogen/incandescent lamps and LEDs
- KNX programming button of the product is under the front cover for easy access
- Product can be flush mounted installed in ceilings with clamps
- Ceiling installation is also possible with surface-mounted box
- 8 independent channels can be used for presence or/and brightness dependent control for lighting, HVAC control etc...
- Test mode for checking function and detection area
- All sensors measurements can be calibrated before ETS programming by parameters or after ETS programming by communication objects
- Alarm function for measurements
- Presence dependent channels can work in parallel (Master/ Slave or Master/Master)
- Short presence function reduces the time delay when device detects movement briefly
- Brightness switching value or set point value can be set in lux before ETS programming by parameters or after ETS programming by communication objects
- Channel's presence and brightness sources can be from internal or/and external sensors
- Independent lock function for each channel
- Channels can be programmed to work with manual switching/dimming (by push buttons for example).
- Participation to scenes

■ TECHNICAL DATA

Supply voltage	21 ... 32V DC via KNX Bus
Ambient temperature	-5°C ... +45°C
Type of protection	IP20 to EN60529
Safety class	III to IEC 60664-1
Detectable movement speed	0.3 m/s ~ 1.0 m/s
Detectable temperature difference	More than 4°C
Brightness measurement	1 ... 3000 lux
Temperature measurement	0°C ... 45°C
Relative humidity	0% ... 100%
Air quality, equivalent carbon dioxide (eCO ₂)	400 ppm ... 8192 ppm.

■ PRODUCT CODES

Product	Product codes
KNX Ceiling Type Presence Detector A100	WRKT32005NC
KNX Ceiling Type Presence Detector A100-T	WRKT32015NC
KNX Ceiling Type Presence Detector A100-TA	WRKT32025NC
Surface Mount Installation Box	WRKT8300-XXX

■ DIMENSIONS

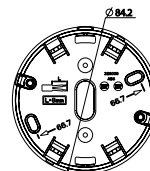

Product Version			
Product Features	WRKT32005NC	WRKT32015NC	WRKT32025NC
	KNX Ceiling Type Presence Detector A100	KNX Ceiling Type Presence Detector A100-T	KNX Ceiling Type Presence Detector A100-TA
Presence detection	✓	✓	✓
Brightness measurement	✓	✓	✓
Temperature measurement	-	✓	✓
Humidity measurement	-	✓	✓
Air quality measurement	-	-	✓

Ceiling

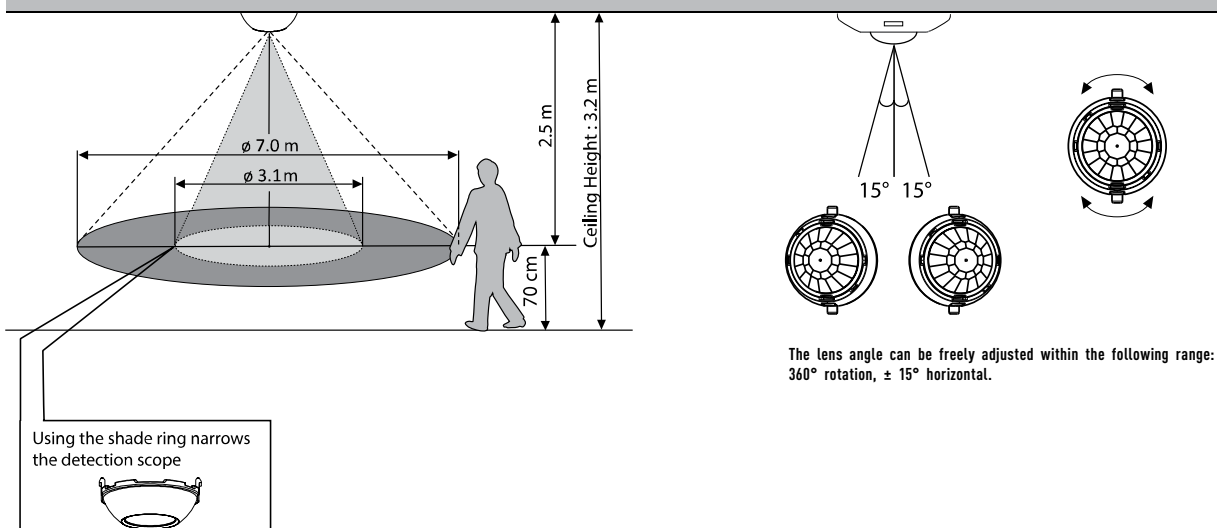

- The scope of detection is different depending on the height of the ceiling (unit:m)
- The shade ring can be used if the detection range of the motion sensor is wanted to be reduced. It can be mounted to the device by pushing it towards the lens

Ceiling height	2.7 m	3.2 m	4.2 m
Guideline height for detection scope setting	2.0 m	2.5 m	3.5 m
Diameter of detection scope without shade ring	Ø 5.6 m	Ø 7.0 m	Ø 9.8 m
Diameter of detection scope with shade ring	Ø 2.5 m	Ø 3.1 m	Ø 4.4 m

Remark: The standard of appropriate height is 70 cm from floor or height from floor to hand of human for detection.

DIMENSIONS

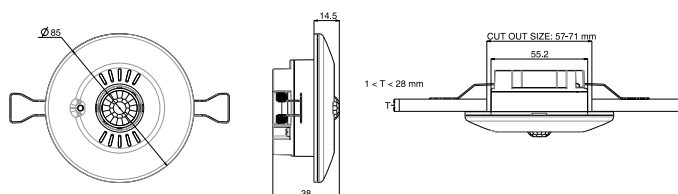

Panasonic

KNX High Bay Mount Presence Detector



MAIN FEATURES

Introducing the KNX High Bay Mount Presence Detector - a cutting-edge solution blending PIR motion and light level detection. Solely designed for seamless integration into the KNX Home and Building Control System, this device revolutionizes lighting and HVAC control, delivering unparalleled automation and energy efficiency.

Upgrade your control system with the KNX High Bay Mount Presence Detector, setting new standards in intelligent automation and energy conservation.

TECHNICAL DATA

Rated voltage	21 30V DC (supply by KNX Bus)
Current consumption EIB/KNX	Operate: Approx. 10mA Standby: Approx 5mA
Connection type	Bus connection terminal Φ 0.8mm, single core
Output	5 channels (2 channels for lighting 2 channels for HVAC 1 channels for Alarm)
Settings	Settable by ETS
Detection range	360° circular, up to Φ 8m at height of 2.5m, up to Φ 16m at height of 10m
Sensitivity	Adjustable via ETS in 4 steps
Light measuring	10 - 2000Lux
Operating temperature	-20°C to +50°C
Environmental protection	IP20
Standard and safety	IEC 61000-6-1 / IEC 61000-6-3 / EN 55014 / EN 50491

DIMENSIONS

KNX High Bay Mount Presence Detector

• Detector with junction box

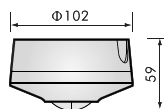
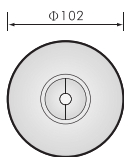

• Detector with power box cap

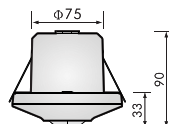
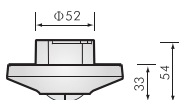

KEY FEATURES

- Versatile presence detection for controlling devices such as lighting, HVAC, and alarm systems
- Designed for KNX (EIB) and TP (twisted pair) bus systems, ensuring compatibility with other KNX components
- Effortless parameter and function settings through ETS 5 (Engineering Tool Software Ver. 5.0)
- High bay design, allowing mounting at heights of up to 10m
- Available in various mounting methods, including surface mount with a junction box and flush mount with a power box cap, both compliant with European standard junction boxes

USAGE OF LENS SHIELD

3.1 KNX High Bay Mount Presence Detector has provided 2 lens shields for masking the undesired detection area. Each lens shield has 3 layers (Layer A / Layer B / Layer C), each layer includes 6 small segments and each small segment can cover 30° detector at the height of 10m, the detection range is as below:

Used lens shield	Covered detection range
None	Φ 16m
Small segment	30° per piece
A+B+C	Φ 1m
A+B	Φ 12m
A	Φ 14m

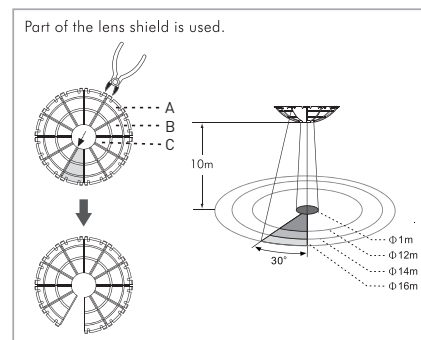

FIG.1

The shadow part of the lens shields in the FIG.1 is referring to the cut off parts.

3.2. After user choosing the desired detection area, the redundant lens shield should be eliminated.

3.3. Fixing lens shield: There is slot around the lens and insert the lens shield into slot (See FIG. 2).

KNX Corridor Type Detector (Surface Mounted) KNX Corridor Type Detector (Flush Mounted)



■ MAIN FEATURES

Experience effortless lighting control and make your lighting smarter and more convenient with Panasonic user-friendly corridor type detector.

■ KEY FEATURES

- Use dual input channels to establish a connection with two separate push buttons, allowing for effortless control over the activation of lighting or the adjustment of dimming levels
- Customize movement detection based on occupancy and ambient brightness
- Simple programming of AUTO or SEMI-AUTO modes via ETS
- Expand detection range by connecting slave sensors to the master sensor
- Stay informed with a red LED indicator for clear movement detection alerts

■ USAGE OF LENS SHIELD

Undesired detection areas can be shielded off by fixing the enclosed lens shield onto the lens.

Trim the lens shield with scissors either horizontally or vertically until the desired detection area is obtained.

Surface Mounted

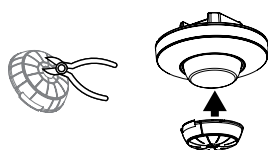

Figure 3

Flush Mounted

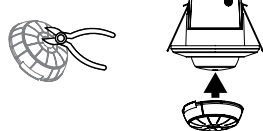

Figure 4

■ TECHNICAL DATA

Model name	WRKT32105NC, WRKT32205NC
Product name	KNX Corridor Type Detector (Surface Mounted) KNX Corridor Type Detector (Flush Mounted)
Rated voltage	24VDC (via KNX bus)
Operating temperature	-20°C ~ +45°C
Current draw	Approx. 10mA
Rated load	Up to 2 KNX devices via KNX bus
Terminal	For WRKT32105NC: 2-pin standard EIB/KNX terminal (Red/Gray or Red/Black) 2-pin push button terminal (S1, S1 & S2, S2)
ETS programming	For WRKT32105NC: Via program button on the sensor
Rated protection	IP20
Detection	40m x 5m, L x W (tangential range) 16m x 3m, L x W (radial range) at 2.5m height, 20°C
Time setting	Time 1 & Time 2: 30 sec - 60 min
Lux setting	Lux 1 & Lux 2: 10 - 2000 lux
Stand by time setting	Standby Time 1 & Time 2: OFF / 1 - 60 min / ON
Standby % setting	Standby Level 1 & Level 2: 10% - 60%

■ INSTALLATION

- With surface mount box (Optional purchase)
1. There are 4 pairs of knockouts with various distances from 56mm to 80mm on the bottom cover of combined surface mount box for different mounting applications (Fig. 5). Select two same figures on both ends for the corresponding distance for fixing (Table 2).
 2. To feed KNX bus cables through the side of surface mount box, please use the cutting pliers to break the cable entry knockouts on the side of surface mount box, then feed the KNX bus cables through the entry and into the surface mount box. Strip off 5 - 6mm of cable sheathing for wiring (Fig. 6).
 3. Choose proper knockouts to fix the surface mount box on the surface of ceiling with 2pcs screws attached with rubber washer (Fig. 7).
 4. Refer to wiring diagrams for correct wiring connection (Fig. 12) and after ETS programming fix the detector into surface mount box with 2pcs non-dropping screws (Fig. 8).
 5. Fix the decorative frame.

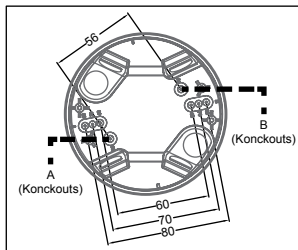

Figure 5

NO.	AB		The distance between A and B
1	56	56	56mm
2	60	60	60mm
3	70	70	70mm
4	80	80	80mm

Table 2

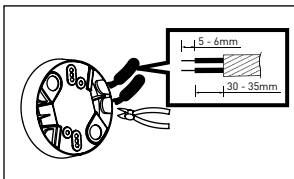

Figure 6

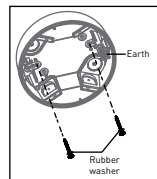

Figure 7

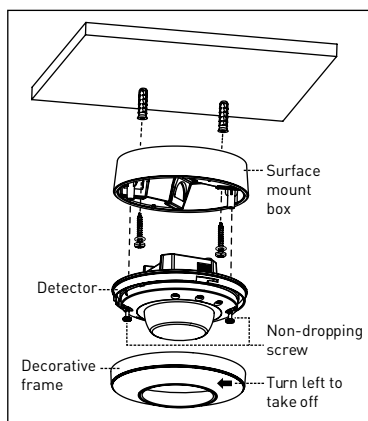

Figure 8

- Ceiling flush mount with spring clips

1. To install the detector, please drill a hole with diameter of 68mm on ceiling board and keep the KNX bus cable outside. Please strip off 5 - 6mm of cable sheathing for wiring (Fig. 9).
2. Please refer to illustration of Fig. 11 for correct installation, and fix the flush mount spring clips to the detector with 2pcs non-dropping screws (Fig. 10).
3. Refer to wiring diagrams for correct wiring connection (Fig. 13) and after ETS programming tighten the flush mount spring clips with 2pcs non-dropping screws (Fig. 10).
4. Raise the two spring clips, and insert the detector into the drilled hole on ceiling (Fig. 11).

■ CONNECTION DIAGRAM

- With surface mount box (Optional purchase)

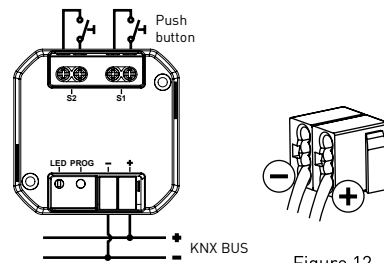

Figure 12

- Ceiling flush mount with spring clips

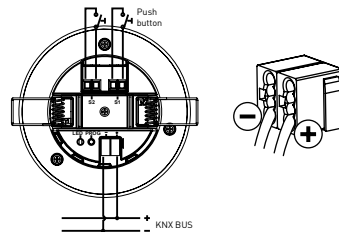
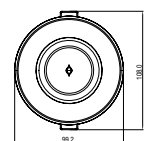
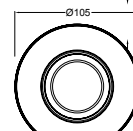
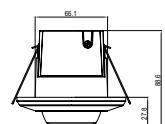
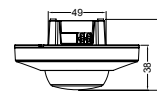

Figure 13

■ DIMENSIONS

KNX Corridor Type Detector (Surface Mounted)

KNX Corridor Type Detector (Flush Mounted)



Detector with Surface Mount Box for WRKT32105NC (optional purchase)

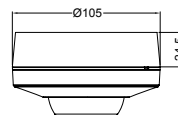

Panasonic Electric Works Elektrik San. ve Tic. A.Ş.

Abdurrahmangazi Mah. Ebubekir Cad. No: 44 34887 Sancaktepe İstanbul / Türkiye
T: +90 [216] 564 55 55 F: +90 [216] 564 55 44 ewtr.panasonic.com info@tr.panasonic.com