

**Panasonic**

**LED**

**LED  
LIGHTING  
CATALOGUE  
2023-2024**

**Illumination that inspires the best in you**

Panasonic Electric Works supports lighting the future. We offer optimum lighting solutions to the overseas market with a wide product range.



**Grand Indonesia**  
Indonesia

**Tokyu Plaza Ginza**  
Japan

**Tenggarong Bridge**  
Indonesia



**Tokyo Skytree**  
Japan







**Gelora Bung Karno Stadium**  
Indonesia



**Prag Castle**  
Czech Republic



	PANASONIC LED STANDART LAMPS / 6		
	PANASONIC LED FILAMENT LAMPS / 12	PANASONIC DIMMABLE LAMPS / 10	
			
	PANASONIC LED TUBE G13 / 18	PANASONIC LED TORCH LAMPS / 14	
	PANASONIC BT WIFI RGB LED LAMPS / 22	PANASONIC REMOTE CONTROL RGB LED LAMP / 20	
			
	PANASONIC LED SPLASH PROOF / 28	PANASONIC LED BACKLIT / 26	
			
	PANASONIC LED SPLASH PROOF / 32	PANASONIC LED SPLASH PROOF SENSOR / 28	
			
	PANASONIC LED CEILING LIGHT / 36	PANASONIC LED FLOODLIGHT SENSOR / 32	
	PANASONIC LED DOWNLIGHT / 40	PANASONIC USB DESK LAMP / 38	

## **Panasonic LED Standard Lamps**

Panasonic illuminates your home with its products that combine high technology, superior performance, safety and design. The LED lamps series provides light temperatures up to 2700K, 3000K, 4000K, 6500K with warm white, cool white, neutral white options, every point of living spaces, from kitchens to study rooms, meets with ideal quality lighting.

E14, E27, GU10 type led lamps from power energy offers high energy efficacy up to 109lm/W while creating alight and homey spaces with clean and panoramic angle thanks to it cutting edge technology.

Enlightening the world  
**with Panasonic safe and efficient lighting**



# Excellent LED Standart Lamps within gorgeous classic apperance

### Product Features:

- Long life up to 15,000 hours
- 2700K/4000K/6500K color temperature options
- Energy efficiency up to 109 lm/W

### Application Areas:

- Residance
- Office
- General lighting



E14



Product Code	Product Description	Power (W)	Equivalent Power (W)	Operating Voltage (V)	Color Rendering Index (Ra)	Color Temperature	Luminous Flux (lm)	Efficiency Factor (lm/W)	Energy Class	Light Beam Angle	Size (B) (mm)	Diameter (E) (mm)	Quantity in Box
LDCH05LG3T4	PANASONIC LED E14 4,9W 470LM 2700K	4,9	40	220-240	≥80	2700K	470	96	F	240°	100	37	100
LDCH05WG3T4	PANASONIC LED E14 4,9W 470LM 4000K	4,9	40	220-240	≥80	4000K	470	96	F	240°	100	37	100
LDCH05DG3T4	PANASONIC LED E14 4,9W 470LM 6500K	4,9	40	220-240	≥80	6500K	470	96	F	240°	100	37	100
LDCH07LG3T4	PANASONIC LED E14 6,5W 640LM 2700K	6,5	50	220-240	≥80	2700K	640	99	F	240°	106	37	100
LDCH07WG3T4	PANASONIC LED E14 6,5W 640LM 4000K	6,5	50	220-240	≥80	4000K	640	99	F	240°	106	37	100
LDCH07DG3T4	PANASONIC LED E14 6,5W 640LM 6500K	6,5	50	220-240	≥80	6500K	640	99	F	240°	106	37	100

E27



Product Code	Product Description	Power (W)	Equivalent Power (W)	Operating Voltage (V)	Color Rendering Index (Ra)	Color Temperature	Luminous Flux (lm)	Efficiency Factor (lm/W)	Energy Class	Light Beam Angle	Size (B) (mm)	Diameter (E) (mm)	Quantity in Box
LDACH05LG3T7	PANASONIC LED E27 4,9W 470LM 2700K	4,9	40	220-240	≥80	2700K	470	96	F	200°	107	60	100
LDACH05WG3T7	PANASONIC LED E27 4,9W 515LM 4000K	4,9	43	220-240	≥80	4000K	515	105	F	200°	107	60	100
LDACH05DG3T7	PANASONIC LED E27 4,9W 515LM 6500K	4,9	43	220-240	≥80	6500K	515	105	F	200°	107	60	100
LDACH09LG3T7	PANASONIC LED E27 8,5W 806LM 2700K	8,5	60	220-240	≥80	2700K	806	95	F	200°	107	60	100
LDACH09WG3T7	PANASONIC LED E27 8,5W 860LM 4000K	8,5	63	220-240	≥80	4000K	860	101	F	200°	107	60	100
LDACH09DG3T7	PANASONIC LED E27 8,5W 860LM 6500K	8,5	63	220-240	≥80	6500K	860	101	F	200°	107	60	100
LDACH11LG3T7	PANASONIC LED E27 10,5W 1055LM 2700K	10,5	75	220-240	≥80	2700K	1.055	101	F	200°	111	60	100
LDACH11WG3T7	PANASONIC LED E27 10,5W 1055LM 4000K	10,5	75	220-240	≥80	4000K	1.055	101	F	200°	111	60	100
LDACH11DG3T7	PANASONIC LED E27 10,5W 1055LM 6500K	10,5	75	220-240	≥80	6500K	1.055	101	F	200°	111	60	100
LDACH14LG3T7	PANASONIC LED E27 14W 1521LM 2700K	14	100	220-240	≥80	2700K	1.521	109	F	200°	120	60	100
LDACH14WG3T7	PANASONIC LED E27 14W 1521LM 4000K	14	100	220-240	≥80	4000K	1.521	109	F	200°	120	60	100
LDACH14DG3T7	PANASONIC LED E27 14W 1521LM 6500K	14	100	220-240	≥80	6500K	1.521	109	F	200°	120	60	100

GU10



Product Code	Product Description	Power (W)	Equivalent Power (W)	Operating Voltage (V)	Color Rendering Index (Ra)	Color Temperature	Luminous Flux (lm)	Efficiency Factor (lm/W)	Energy Class	Light Beam Angle	Size (B) (mm)	Diameter (E) (mm)	Quantity in Box
LDRCH04LN4T1	PANASONIC LED GU10 4W 310LM 2700K	4	45	220-240	≥80	2700K	310	78	F	39°	54	50	150
LDRCH04LN3T1	PANASONIC LED GU10 4W 310LM 3000K	4	45	220-240	≥80	3000K	310	78	F	39°	54	50	150
LDRCH04WN3T1	PANASONIC LED GU10 4W 345LM 4000K	4	50	220-240	≥80	4000K	345	86	F	39°	54	50	150
LDRCH04DN3T1	PANASONIC LED GU10 4W 345LM 6500K	4	50	220-240	≥80	6500K	345	86	F	39°	54	50	150
LDRCH06LN4T1	PANASONIC LED GU10 6W 420LM 2700K	6	60	220-240	≥80	2700K	420	70	G	39°	54	50	150
LDRCH06LN3T1	PANASONIC LED GU10 6W 420LM 3000K	6	60	220-240	≥80	3000K	420	70	G	39°	54	50	150
LDRCH06WN3T1	PANASONIC LED GU10 6W 440LM 4000K	6	62	220-240	≥80	4000K	440	73	F	39°	54	50	150
LDRCH06DN3T1	PANASONIC LED GU10 6W 440LM 6500K	6	62	220-240	≥80	6500K	440	73	F	39°	54	50	150
LDRCH04LW4T1	PANASONIC LED GU10 4W 310LM 2700K 60°	4	45	220-240	≥80	2700K	310	78	F	60°	54	50	150
LDRCH04LW3T1	PANASONIC LED GU10 4W 310LM 3000K 60°	4	45	220-240	≥80	3000K	310	78	F	60°	54	50	150
LDRCH04WW3T1	PANASONIC LED GU10 4W 345LM 4000K 60°	4	50	220-240	≥80	4000K	345	86	F	60°	54	50	150
LDRCH04DW3T1	PANASONIC LED GU10 4W 345LM 6500K 60°	4	50	220-240	≥80	6500K	345	86	F	60°	54	50	150
LDRCH06LW4T1	PANASONIC LED GU10 6W 420LM 2700K 60°	6	60	220-240	≥80	2700K	420	70	G	60°	54	50	150
LDRCH06LW3T1	PANASONIC LED GU10 6W 430LM 3000K 60°	6	61	220-240	≥80	3000K	430	70	G	60°	54	50	150
LDRCH06WW3T1	PANASONIC LED GU10 6W 440LM 4000K 60°	6	62	220-240	≥80	4000K	440	73	F	60°	54	50	150
LDRCH06DW3T1	PANASONIC LED GU10 6W 440LM 6500K 60°	6	62	220-240	≥80	6500K	440	73	F	60°	54	50	150

Light brightness is in your control with the energy saving, LED Dimmable Lamps that allow you to adjust the lighting level.

#### Product Features:

- Light brightness control
- 2700K/4000K/6500K colour temperature options
- Compatible with Dim Switches\* and KNX Automation Switches

#### Application Areas:

- Residence
- Office
- General lighting

\* RC 400W Dimmerler ve Universal Dimmerler ile uyumludur.



Dimmable



240°



2700K/4000K/6500K



E14



15.000 Hour



Energy Class



IP 20



CRI



Class

E14

Product Code	Product Description	Power (W)	Equivalent Power (W)	Operating Voltage (V)	Color Rendering Index (Ra)	Color Temperature	Luminous Flux (lm)	Efficiency Factor (lm/W)	Energy Class	Light Beam Angle	Size (B) (mm)	Diameter (E) (mm)	Quantity in Box
LDCC05LGDR4	PANASONIC E14 LED DIM LAMP 4,7W 470LM 2700K	4,7	40	220-240	≥80	2700K	470	100	F	240°	107	37	100
LDCC05WGDR4	PANASONIC E14 LED DIM LAMP 4,7W 470LM 4000K	4,7	40	220-240	≥80	4000K	470	100	F	240°	107	37	100
LDCC05DGDR4	PANASONIC E14 LED DIM LAMP 4,7W 470LM 6500K	4,7	40	220-240	≥80	6500K	470	100	F	240°	107	37	100

E27



200°



2700K/4000K/6500K



E27



15.000 Hour



Energy Class



IP 20



CRI



Class



Dimmable

Product Code	Product Description	Power (W)	Equivalent Power (W)	Operating Voltage (V)	Color Rendering Index (Ra)	Color Temperature	Luminous Flux (lm)	Efficiency Factor (lm/W)	Energy Class	Light Beam Angle	Size (B) (mm)	Diameter (E) (mm)	Quantity in Box
LDACH09LGDR7	PANASONIC E27 LED DIM LAMP 8.5W 806LM 2700K	8,5	60	220-240	≥80	2700K	806	95	F	200°	111	60	100
LDACH09WGDR7	PANASONIC E27 LED DIM LAMP 8.5W 806LM 4000K	8,5	60	220-240	≥80	4000K	806	95	F	200°	111	60	100
LDACH09DGDR7	PANASONIC E27 LED DIM LAMP 8.5W 806LM 6500K	8,5	60	220-240	≥80	6500K	806	95	F	200°	111	60	100
LDACH11LGDR7	PANASONIC E27 LED DIM LAMP 10.5W 1055LM 2700K	10,5	75	220-240	≥80	2700K	1.055	100	F	200°	120	60	100
LDACH11WGDR7	PANASONIC E27 LED DIM LAMP 10.5W 1055LM 4000K	10,5	75	220-240	≥80	4000K	1.055	100	F	200°	120	60	100
LDACH11DGDR7	PANASONIC E27 LED DIM LAMP 10.5W 1055LM 6500K	10,5	75	220-240	≥80	6500K	1.055	100	F	200°	120	60	100

GU10



39°



2700K/3000K  
4000K/6500K



GU10



15.000 Hour



Energy Class



IP 20



CRI



Class



Dimmable

Product Code	Product Description	Power (W)	Equivalent Power (W)	Operating Voltage (V)	Color Rendering Index (Ra)	Color Temperature	Luminous Flux (lm)	Efficiency Factor (lm/W)	Energy Class	Light Beam Angle	Size (B) (mm)	Diameter (E) (mm)	Quantity in Box
LDRCH04LWDR1	PANASONIC GU10 LED DIM LAMP 4W 310LM 2700K	4	45	220-240	≥80	2700K	310	78	F	39°	54	50	150
LDRCH04WWDR1	PANASONIC GU10 LED DIM LAMP 4W 310LM 3000K	4	45	220-240	≥80	3000K	310	78	F	39°	54	50	150
LDRCH04WWDR2	PANASONIC GU10 LED DIM LAMP 4W 310LM 4000K	4	45	220-240	≥80	4000K	310	78	F	39°	54	50	150
LDRCH04DWDR1	PANASONIC GU10 LED DIM LAMP 4W 310LM 6500K	4	45	220-240	≥80	6500K	310	78	F	39°	54	50	150

# Panasonic LED Filament Lamps

*The derivation of light.*

Panasonic Filament LED Lamps, available in clear and amber glass color options, offer a retrofit solution. With various models such as classic, candle, retro, and globe, they reflect the unique harmony of technology and design while providing energy efficiency of up to 118 lm/W.

In addition to its excellent light output and a long lifespan of up to 15,000 hours, it offers the ideal solution for both commercial and personal applications with its 360° even light distributio.

**Product Features:**

- RoHS compliant
- 4 different socket types
- Color temperature options of 2000K/2700K
- High efficiency of up to 118 lm/W in energy consumption

**Application Areas:**

- Residence
- Cafe & Restaurant



### E27

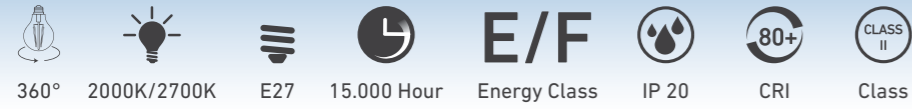

Product Code	Product Description	Power (W)	Equivalent Power (W)	Operating Voltage (V)	Color Rendering Index (Ra)	Color Temperature	Luminous Flux (lm)	Efficiency Factor (lm/W)	Energy Class	Light Beam Angle	Size (B) (mm)	Diameter (E) (mm)	Quantity in Box
LDTC45D61E7	PANASONIC E27 FIL LAMP 4W 470LM 2700K CLEAR	4	40	220-240	≥80	2700K	470	118	E	360°	105	60	80
LDACH04LH1EA	PANASONIC E27 FIL LAMP 4W 360LM 2000K GOLD	4	40	220-240	≥80	2000K	360	90	F	360°	105	60	80
LDACH07LH1EC	PANASONIC E27 FIL LAMP 7W 806LM 2700K CLEAR	7	60	220-240	≥80	2700K	806	115	E	360°	105	60	80
LDACH07LH1EA	PANASONIC E27 FIL LAMP 7W 630LM 2000K GOLD	7	60	220-240	≥80	2000K	630	90	F	360°	105	60	80

### E14



Product Code	Product Description	Power (W)	Equivalent Power (W)	Operating Voltage (V)	Color Rendering Index (Ra)	Color Temperature	Luminous Flux (lm)	Efficiency Factor (lm/W)	Energy Class	Light Beam Angle	Size (B) (mm)	Diameter (E) (mm)	Quantity in Box
LDCC02LH1EC	PANASONIC E14 FIL LAMP 2W 200LM 2700K CLEAR	2,2	25	220-240	≥80	2700K	200	91	F	360°	97	35	100
LDCC02LH1EA	PANASONIC E14 FIL LAMP 2W 150LM 2000K GOLD	2,2	25	220-240	≥80	2000K	150	68	G	360°	97	35	100
LDCC04LH1EC	PANASONIC E14 FIL LAMP 4W 470LM 2700K CLEAR	4	40	220-240	≥80	2700K	470	118	E	360°	97	35	100
LDCC04LH1EA	PANASONIC E14 FIL LAMP 4W 360LM 2000K GOLD	4	40	220-240	≥80	2000K	360	90	F	360°	97	35	100

### ST64



Product Code	Product Description	Power (W)	Equivalent Power (W)	Operating Voltage (V)	Color Rendering Index (Ra)	Color Temperature	Luminous Flux (lm)	Efficiency Factor (lm/W)	Energy Class	Light Beam Angle	Size (B) (mm)	Diameter (E) (mm)	Quantity in Box
LDSCH04LH1EC	PANASONIC E27 FIL ST64 LAMP 4W 470LM 2700K CLEAR	4	40	220-240	≥80	2700K	470	118	E	360°	140	64	60
LDSCH04LH1EA	PANASONIC E27 FIL ST64 LAMP 4W 360LM 2000K GOLD	4	40	220-240	≥80	2000K	360	90	F	360°	140	64	60
LDSCH07LH1EC	PANASONIC E27 FIL ST64 LAMP 7W 806LM 2700K CLEAR	7	60	220-240	≥80	2700K	806	115	E	360°	140	64	60
LDSCH07LH1EA	PANASONIC E27 FIL ST64 LAMP 7W 630LM 2000K GOLD	7	60	220-240	≥80	2000K	630	90	F	360°	140	64	60

### G95 / G125



Product Code	Product Description	Power (W)	Equivalent Power (W)	Operating Voltage (V)	Color Rendering Index (Ra)	Color Temperature	Luminous Flux (lm)	Efficiency Factor (lm/W)	Energy Class	Light Beam Angle	Size (B) (mm)	Diameter (E) (mm)	Quantity in Box
LDGCH07LH2EC	PANASONIC E27 FIL G95 LAMP 7W 806LM 2700K CLEAR	7	60	220-240	≥80	2700K	806	115	E	360°	138	95	40
LDGCH07LH2EA	PANASONIC E27 FIL G95 LAMP 7W 630LM 2000K GOLD	7	60	220-240	≥80	2000K	630	90	F	360°	138	95	40
LDGCH07LH1EC	PANASONIC E27 FIL G125 LAMP 7W 806LM 2700K CLEAR	7	60	220-240	≥80	2700K	806	115	E	360°	173	125	40
LDGCH07LH1EA	PANASONIC E27 FIL G125 LAMP 7W 630LM 2000K GOLD	7	60	220-240	≥80	2000K	630	90	F	360°	173	125	40



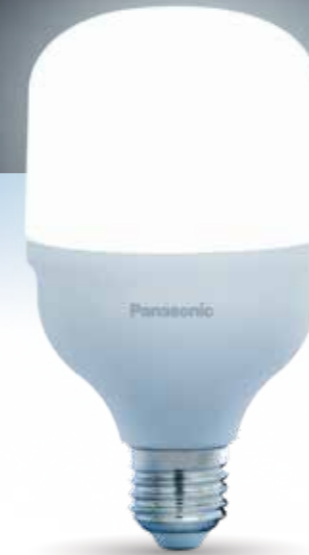

E27

 200°
  3000K/4000K/6500K
  E27
  15.000 Hour
  E/F
  IP 20
  80+
  CLASS II

While Torch lamps provide energy efficiency up to 131lm/W, they can easily be inserted instead of standard lamps thanks to classical E27 socket and in this way; they allow easy installation in retail and personal applications. Torch lamps offer more homogeneous lighting with four different power options of 18W, 23W, 35W, 45W and color temperatures of 3000K, 4000K, 6500K.

**Product Features:**

- 18W-23W-35W-45W power options
- Long life up to 15000 hour with excellent luminosity
- 3000K/4000K/6000K color temperature options

**Application Areas:**

- Commercial
- Market

Product Code	Product Description	Power (W)	Equivalent Power (W)	Operating Voltage (V)	Color Rendering Index (Ra)	Color Temperature	Luminous Flux (lm)	Efficiency Factor (lm/W)	Energy Class	Light Beam Angle	Size (B) (mm)	Diameter (E) (mm)	Quantity in Box
LDTC18LG1E7	PANASONIC E27 TORCH LED LAMP 18W 1860LM 3000K	18	100	220-240	≥80	3000K	1.860	103	F	200°	142	80	30
LDTC18WG1E7	PANASONIC E27 TORCH LED LAMP 18W 1980LM 4000K	18	100	220-240	≥80	4000K	1.980	110	E	200°	142	80	30
LDTC18DG1E7	PANASONIC E27 TORCH LED LAMP 18W 2040LM 6500K	18	100	220-240	≥80	6500K	2.040	113	E	200°	142	80	30
LDTC23LG1E7	PANASONIC E27 TORCH LED LAMP 23W 2430LM 3000K	23	100	220-240	≥80	3000K	2.430	106	F	200°	166	100	20
LDTC23WG1E7	PANASONIC E27 TORCH LED LAMP 23W 2600LM 4000K	23	100	220-240	≥80	4000K	2.600	113	E	200°	166	100	20
LDTC23DG1E7	PANASONIC E27 TORCH LED LAMP 23W 2650LM 6500K	23	100	220-240	≥80	6500K	2.650	115	E	200°	166	100	20
LDTC35LG1E7	PANASONIC E27 TORCH LED LAMP 35W 4140LM 3000K	35	150	220-240	≥80	3000K	4.140	118	E	200°	202	118	20
LDTC35WG1E7	PANASONIC E27 TORCH LED LAMP 35W 4570LM 4000K	35	150	220-240	≥80	4000K	4.570	131	E	200°	202	118	20
LDTC35DG1E7	PANASONIC E27 TORCH LED LAMP 35W 4190LM 6500K	35	150	220-240	≥80	6500K	4.190	120	E	200°	202	118	20
LDTC45LG1E7	PANASONIC E27 TORCH LED LAMP 45W 5250LM 3000K	45	200	220-240	≥80	3000K	5.250	117	E	200°	228	138	8
LDTC45WG1E7	PANASONIC E27 TORCH LED LAMP 45W 5330LM 4000K	45	200	220-240	≥80	4000K	5.330	119	E	200°	228	138	8
LDTC45DG1E7	PANASONIC E27 TORCH LED LAMP 45W 5370LM 6500K	45	200	220-240	≥80	6500K	5.370	119	E	200°	228	138	8



LED TUBE T8

**Product Features:**

- Easy installation
- Color temperature options of 3000K/4000K/6500K
- Short circuit protected design

**Application Areas:**

- Hospital
- School
- Workplace



Product Code	Product Description	Power (W)	Operating Voltage (V)	Color Rendering Index (Ra)	Color Temperature	Luminous Flux (lm)	Efficiency Factor (lm/W)	Energy Class	Product Size (mm)	Quantity in Box
BPT100S830TA	PANASONIC LED TUBE T8 9W 1000LM 60CM G13 3000K	9	220-240	≥80	3000K	1000	111	E	600*Ø25,4	25
BPT100S840TA	PANASONIC LED TUBE T8 9W 1000LM 60CM G13 4000K	9	220-240	≥80	4000K	1000	111	E	600*Ø25,4	25
BPT100S865TA	PANASONIC LED TUBE T8 9W 1000LM 60CM G13 6500K	9	220-240	≥80	6500K	1000	111	E	600*Ø25,4	25
BPT200M830TA	PANASONIC LED TUBE T8 18W 2000LM 120CM G13 3000K	18	220-240	≥80	3000K	2000	111	E	1200*Ø25,4	25
BPT200M840TA	PANASONIC LED TUBE T8 18W 2000LM 120CM G13 4000K	18	220-240	≥80	4000K	2000	111	E	1200*Ø25,4	25
BPT200M865TA	PANASONIC LED TUBE T8 18W 2000LM 120CM G13 6500K	18	220-240	≥80	6500K	2000	111	E	1200*Ø25,4	25

**Installation:**

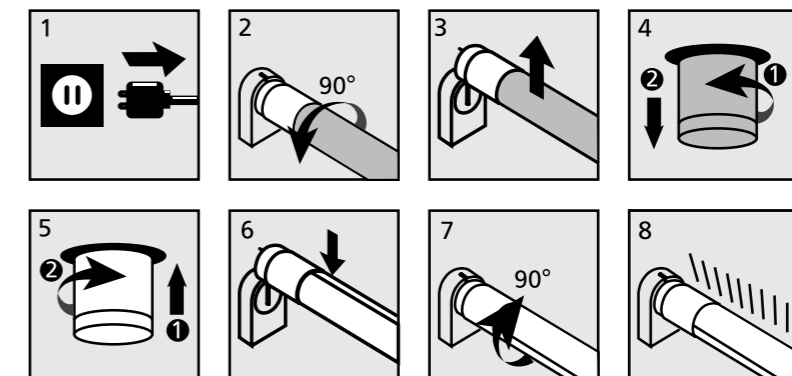

Compatible both for fixtures with magnetic balast and 220V products. Starter is included in box.

Panasonic LED Tube T8

Modern lighting that facilitates the transition to new technology.

Panasonic LED Tube facilitates the transition from traditional technology to modern LED lighting products with its plug-and-play concept. It offers an environmentally friendly lighting solution with its long lifespan and energy-saving benefits.

# Panasonic Remote Control RGB LED Lamp

*Very colorful, very stylish.*

The Panasonic Remote Control Lamp with color-changing, dimmable RGB-2700K light adds color and elegance to any environment.



## REMOTE CONTROL LED LAMP

200° 2700K E27 15.000 Hour Energy Class F IP 20 80+ CRI CLASS II



Controlled

Panasonic Remote Control RGB Lamp with dimmable RGB-2700K light adds color and elegance to every environment..

### Product Features:

- 2700K+RGB color options
- Multi-colored and stylish
- Easy remote control
- 4 lighting modes ; Flash, Strobe, Fade and Smooth

### Application Areas:

- Residential
- Stage lighting
- Architectural lighting

Product Code	Product Description	Power (W)	Equivalent Power (W)	Operating Voltage (V)	Color Rendering Index (Ra)	Color Temperature	Luminous Flux (lm)	Efficiency Factor (lm/W)	Energy Class	Light Beam Angle	Size (B) (mm)	Diameter (E) (mm)	Quantity in Box
LDACH09LGR7	PANASONIC E27 LED SMART REMOTE CONTROLLED LAMP 9W RGB	9	60	220-240	≥80	RGB+2700K	806	90	F	200°	114	60	100



# Panasonic Smart BT Wi-Fi RGB LED Lamp Series

*Very colorful, very smart.*

With the application-controlled dimmable RGB+White light from the Panasonic Smart Lamp Series, you can swiftly and effortlessly bring color and enjoyment to any environment.



Very colorful,  
very smart.

Panasonic Smart Lamp Series with dimmable RGB+White light add color and fun to every space with minimum effort thanks to its controllability over the application.

#### Product Features:

- Connection via Wi-Fi and Bluetooth
- Compatibility with Circadian rhythm
- Voice Assistant programmable feature
- Control via Tuya, Amazon Alexa, Google Assistant
- 2700K~6500K + RGB

#### Application Areas:

- Residential
- Stage lighting
- Architectural lighting



E14

200° 2700K/6500K E14 15.000 Hour Energy Class IP 20 CRI 80+ CLASS II

Control via App. Dimmable via App. BT - Wi-Fi Control Voice Assistant Scheduling Circadian Rhythm

Product Code	Product Description	Power (W)	Equivalent Power (W)	Operating Voltage (V)	Color Rendering Index (Ra)	Color Temperature	Luminous Flux (lm)	Efficiency Factor (lm/W)	Energy Class	Light Beam Angle	Size (B) (mm)	Diameter (E) (mm)	Quantity in Box
LDCCH05AGSR4	PANASONIC LED SMART BT WIFI RGB E14 LAMBA 4,9W	4,9	40	220-240	≥80	RGB+2700K-6500K	470	95	F	200°	107	37,5	60

E27



200° 2700K/6500K E27 15.000 Hour Energy Class IP 20 CRI 80+ CLASS II

Control via App. Dimmable via App. BT - Wi-Fi Control Voice Assistant Scheduling Circadian Rhythm

Product Code	Product Description	Power (W)	Equivalent Power (W)	Operating Voltage (V)	Color Rendering Index (Ra)	Color Temperature	Luminous Flux (lm)	Efficiency Factor (lm/W)	Energy Class	Light Beam Angle	Size (B) (mm)	Diameter (E) (mm)	Quantity in Box
LDACH09AGSR7	PANASONIC LED SMART BT WIFI RGB E27 LAMBA 9W	8,5	60	220-240	≥80	RGB+2700K-6500K	800	90	F	200°	113	60	60

GU10



40° 2700K/6500K GU10 15.000 Hour Energy Class IP 20 CRI 80+ CLASS II

Control via App. Dimmable via App. BT - Wi-Fi Control Voice Assistant Scheduling Circadian Rhythm

Product Code	Product Description	Power (W)	Equivalent Power (W)	Operating Voltage (V)	Color Rendering Index (Ra)	Color Temperature	Luminous Flux (lm)	Efficiency Factor (lm/W)	Energy Class	Light Beam Angle	Size (B) (mm)	Diameter (E) (mm)	Quantity in Box
LDRCH05AWSR1	PANASONIC LED SMART BT WIFI RGB GU10 LAMBA 4,9W	4,9	51	220-240	≥80	RGB+2700K-6500K	350	84	G	40°	54	50	60

## Panasonic LED Backlit Panel

Precise balance of light.



### LED BACKLIT PANEL



It delivers a high efficacy value with 30.000h life time. Flush mounted directly against the ceiling, suitable undoubtedly for office, retail, education and hospitality with its different size of (dimensions) 600x600mm and 300x1200mm body options and accessories are available for different ceiling and installation types.

#### Product Features:

- TSE Certified
- Excellent efficiency with up to 110 lm/W energy consumption
- Long lifespan of 30,000 hours with Panasonic LED Driver
- Two color temperature options (4000K, 6500K)
- Accessories suitable for various ceiling and mounting types



Turkish Standards Institution

#### Application Areas:

- Hospital
- Office
- School
- Hotel

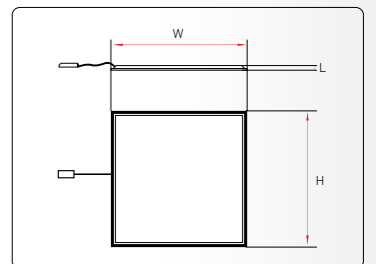

Product Code	Product Description	Power (W)	Input Voltage (V)	Ra	CCT	Lumen (lm)	Energy Class	Product Size (mm)	Quantity in Box
NFV60141WT1M	PANASONIC 60X60 BACKLIT 40W 4400LM 840	40	220-240	≥80	4000K	4400	F	595*595*35	2
NFV60143WT1M	PANASONIC 60X60 BACKLIT 40W 4400LM 865	40	220-240	≥80	6500K	4400	F	595*595*35	2
NFV60145WE1M	PANASONIC 30X120 BACKLIT 40W 4400LM 840	40	220-240	≥80	4000K	4400	F	295*1195*35	6
NFV60147WE1M	PANASONIC 30X120 BACKLIT 40W 4400LM 865	40	220-240	≥80	6500K	4400	F	295*1195*35	6

#### Accessories

Product No	Description	Outer Carton Qty (pcs)	Corresponding Backlit Panel
NFV90015WE1M	PANASONIC LED BACKLIT PANEL PLASTER BOARD CEILING MOUNTING KIT	100pcs	40W: NFV60141WT1M, NFV60143WT1M, NFV60145WE1M, NFV60147WE1M
NFV90016WE1M	PANASONIC LED BACKLIT PANEL PENDANT MOUNTING KIT	100pcs	40W: NFV60141WT1M, NFV60143WT1M, NFV60145WE1M, NFV60147WE1M
NFV90017WE1M	PANASONIC LED BACKLIT PANEL SURFACE MOUNTING FRAME (60x60)	20pcs	40W 2x2: NFV60141WT1M, NFV60143WT1M
NFV90018WE1M	PANASONIC LED BACKLIT PANEL SURFACE MOUNTING FRAME (30x120)	20pcs	40W 1x4: NFV60145WE1M, NFV60147WE1M

## Panasonic LED Splash Proof Panasonic LED Splash Proof Sensor

*Professional lighting under harsh conditions.*

Panasonic LED Splash Proof is designed in an aesthetic and natural form to be suitable for industrial, commercial and residential environments. It is a good alternative to traditional fluorescent type luminaires due to its energy efficiency, superior life span with 25000hr and low maintenance cost. With Panasonic LED Splash Proof Sensor; security is no longer an issue due to its motion-sensitive sensors. Because of its durability to adverse situations, it offers you comfortable environments by supplying constant and uninterrupted light.



LED SPLASH PROOF



It can be integrated with the applications that need high luminous intensity. Panasonic Splash Proof reflects Panasonic quality with homogenous light distribution not straining eyes thanks to poly-carbon optic diffuser.

While it provides a wider area illumination by reducing eye dazzling with 36 Watt and 45 Watt power options and 4000K, 6500K color temperatures, it offers high energy efficiency up to 111lm/W. Panasonic Splash Proof is easily installed with 120 cm and 150 cm compact dimensions and always preferred in the projects with its IP65 protection class in indoor and outdoor environment where water and moisture widely exist.

Product Features:

- 2 different lumen package and length option
- 4000K/6500K color options
- Easy Installation
- IP65 protection rate

Application Areas:

- Residential
- Commercial
- Industrial

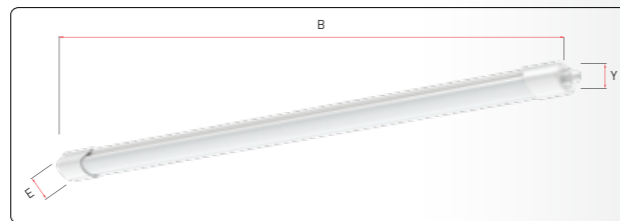

Product Code	Product Description	Power (W)	IP	Operating Voltage (V)	Color Rendering Index (Ra)	Color Temperature	Luminous Flux (lm)	Efficiency Factor (lm/W)	Power Factor (P.F.)	Energy Class	Product Size B*E*Y (mm)	Quantity in Box
NNFC4033154	PANASONIC LED SPLASH PROOF 36W 3960LM 1200MM 840	36	IP65	220-240	≥80	4000K	3960	110	0,9	E	1212*70.5*50.6	20
NNFC4038154	PANASONIC LED SPLASH PROOF 36W 3960LM 1200MM 865	36	IP65	220-240	≥80	6500K	3960	110	0,9	E	1212*70.5*50.6	20
NNFC4033254	PANASONIC LED SPLASH PROOF 45W 5000LM 1500MM 840	45	IP65	220-240	≥80	4000K	5000	111	0,9	E	1500*70.5*50.6	20
NNFC4038254	PANASONIC LED SPLASH PROOF 45W 5000LM 1500MM 865	45	IP65	220-240	≥80	6500K	5000	111	0,9	E	1500*70.5*50.6	20

LED SPLASH PROOF SENSOR



The luminaire will light up if it detects any human or object movement. Induction range max to 6.5m.

The luminaire will enter a 60s delay if it does not detects any human or object movement after the leaving of the persons, while keep lighting. After the 60s delay, the luminaire will automatically turn off.

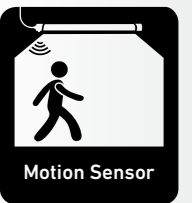

Product Features:

- Motion detecting Radar Sensor
- Detection area with 3 m high installation and a diameter of 6,5 m
- Closing 60 seconds later when no motion is detected
- 2 different lumen and length options
- 4000K/6500K color temperatures

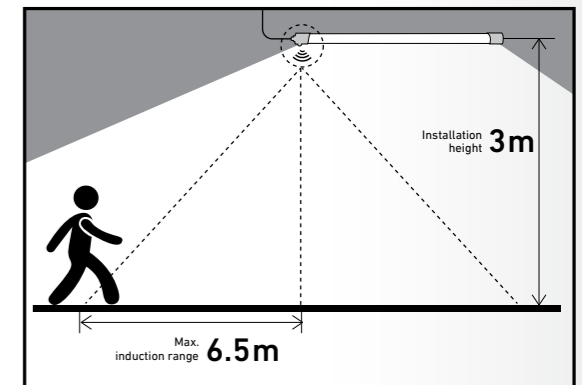

Application Areas:

- Residential
- Commercial
- Industrial

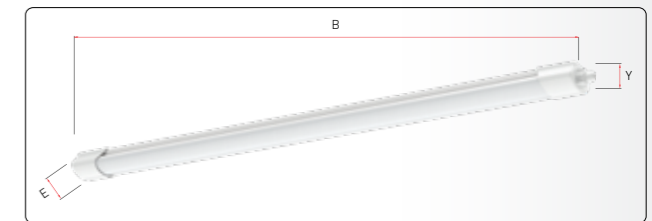

Product Code	Product Description	Power (W)	IP	Operating Voltage (V)	Color Rendering Index (Ra)	Color Temperature	Luminous Flux (lm)	Efficiency Factor (lm/W)	Power Factor (P.F.)	Energy Class	Product Size B*E*Y (mm)	Quantity in Box
NFV30501WE1E	PANASONIC LED SPLASH PROOF SENSOR 36W 3960LM 1200MM 840	36	IP65	220-240	≥80	4000K	3960	152	0,9	E	1212*71*51	20
NFV30503WE1E	PANASONIC LED SPLASH PROOF SENSOR 36W 3960LM 1200MM 865	36	IP65	220-240	≥80	6500K	3960	152	0,9	E	1212*71*51	20
NFV30504WE1E	PANASONIC LED SPLASH PROOF SENSOR 45W 5000LM 1500MM 840	45	IP65	220-240	≥80	4000K	5000	111	0,9	E	1500*71*51	20
NFV30506WE1E	PANASONIC LED SPLASH PROOF SENSOR 45W 5000LM 1500MM 865	45	IP65	220-240	≥80	6500K	5000	111	0,9	E	1500*71*51	20



*Floodlight Family is Expanding*

**Panasonic LED Floodlight**  
**Panasonic LED Floodlight Sensor**

*Quality, security, design...*

The Panasonic LED Floodlight is a compact floodlight series that offers excellent light output with a lifespan of up to 30,000 hours and superior efficiency. It provides a wide range of products with color temperatures of 3000K, 4000K, and 6500K, and a power range of 10 to 300 watts.

The Panasonic Sensor-Enabled LED Floodlight, with its built-in motion and daylight sensor, meets both energy efficiency and safety expectations, making it an ideal solution for outdoor lighting.

Our floodlight family is expanding. The Panasonic LED Floodlight 300W offers superior durability against dust and moisture thanks to its IP66 rating. The 300W power option provides high performance and a powerful lighting solution.





## LED FLOODLIGHT

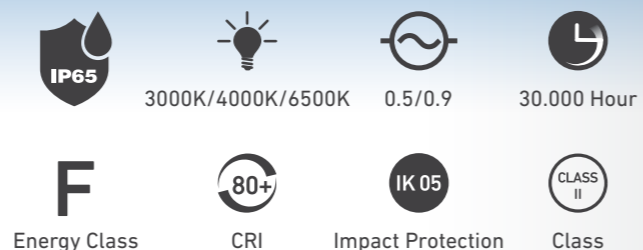

### Product Features:

- Color options of 3000K/4000K/6500K
- Wide product range from 10W to 300W
- IP65 / IP66 protection class
- IK05 / IK06 impact protection

### Application Areas:

- Exterior lighting
- Parking lot
- Factory

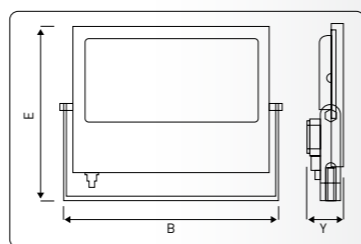

Product Code	Product Description	Power (W)	IP	Operating Voltage (V)	Color Rendering Index (Ra)	Color Temperature	Luminous Flux (lm)	Efficiency Factor (lm/W)	Power Factor (P.F.)	Energy Class	Product Size B*E*Y (mm)	Quantity in Box
NYV00021BE1E	PANASONIC LED FLOODLIGHT 10W 820LM 3000K	10	IP65	220-240	≥80	3000K	820	82	0,5	F	91*90*27	30
NYV00031BE1E	PANASONIC LED FLOODLIGHT 10W 850LM 4000K	10	IP65	220-240	≥80	4000K	850	85	0,5	F	91*90*27	30
NYV00071BE1E	PANASONIC LED FLOODLIGHT 10W 900LM 6500K	10	IP65	220-240	≥80	6500K	900	90	0,5	F	91*90*27	30
NYV00022BE1E	PANASONIC LED FLOODLIGHT 20W 1510LM 3000K	20	IP65	220-240	≥80	3000K	1.510	76	0,5	F	101*97*27	30
NYV00032BE1E	PANASONIC LED FLOODLIGHT 20W 1590LM 4000K	20	IP65	220-240	≥80	4000K	1.590	80	0,5	F	101*97*27	30
NYV00072BE1E	PANASONIC LED FLOODLIGHT 20W 1660LM 6500K	20	IP65	220-240	≥80	6500K	1.660	83	0,5	F	101*97*27	30
NYV00033BE1E	PANASONIC LED FLOODLIGHT 30W 2450LM 3000K	30	IP65	220-240	≥80	3000K	2.450	82	0,9	F	133*124*29	30
NYV00013BE1E	PANASONIC LED FLOODLIGHT 30W 2560LM 4000K	30	IP65	220-240	≥80	4000K	2.560	85	0,9	F	133*124*29	30
NYV00053BE1E	PANASONIC LED FLOODLIGHT 30W 2560LM 6500K	30	IP65	220-240	≥80	6500K	2.560	85	0,9	F	133*124*29	30
NYV00004BE1E	PANASONIC LED FLOODLIGHT 50W 4270LM 3000K	50	IP65	220-240	≥80	3000K	4.270	85	0,9	F	177*146*28	10
NYV00014BE1E	PANASONIC LED FLOODLIGHT 50W 4500LM 4000K	50	IP65	220-240	≥80	4000K	4.500	90	0,9	F	177*146*28	10
NYV00054BE1E	PANASONIC LED FLOODLIGHT 50W 4500LM 6500K	50	IP65	220-240	≥80	6500K	4.500	90	0,9	F	177*146*28	10
NYV00005BE1E	PANASONIC LED FLOODLIGHT 70W 5850LM 3000K	70	IP65	220-240	≥80	3000K	5.850	84	0,9	F	218*173*34	10
NYV00015BE1E	PANASONIC LED FLOODLIGHT 70W 5890LM 4000K	70	IP65	220-240	≥80	4000K	5.980	85	0,9	F	218*173*34	10
NYV00055BE1E	PANASONIC LED FLOODLIGHT 70W 6300LM 6500K	70	IP65	220-240	≥80	6500K	6.300	90	0,9	F	218*173*34	10
NYV00006BE1E	PANASONIC LED FLOODLIGHT 100W 8550LM 3000K	100	IP65	220-240	≥80	3000K	8.550	86	0,9	F	259*220*35	10
NYV00016BE1E	PANASONIC LED FLOODLIGHT 100W 9000LM 4000K	100	IP65	220-240	≥80	4000K	9.000	90	0,9	F	259*220*35	10
NYV00056BE1E	PANASONIC LED FLOODLIGHT 100W 9000LM 6500K	100	IP65	220-240	≥80	6500K	9.000	90	0,9	F	259*220*35	10
NYV00007BE1E	PANASONIC LED FLOODLIGHT 150W 12820LM 3000K	150	IP65	220-240	≥80	3000K	12.820	85	0,9	F	289*262*36	5
NYV00017BE1E	PANASONIC LED FLOODLIGHT 150W 13500LM 4000K	150	IP65	220-240	≥80	4000K	13.500	90	0,9	F	289*262*36	5
NYV00057BE1E	PANASONIC LED FLOODLIGHT 150W 13500LM 6500K	150	IP65	220-240	≥80	6500K	13.500	90	0,9	F	289*262*36	5
NYV00008BE1E	PANASONIC LED FLOODLIGHT 200W 17100LM 3000K	200	IP65	220-240	≥80	3000K	17.100	86	0,9	F	341*310*36	5
NYV00018BE1E	PANASONIC LED FLOODLIGHT 200W 18000LM 4000K	200	IP65	220-240	≥80	4000K	18.000	90	0,9	F	341*310*36	5
NYV00058BE1E	PANASONIC LED FLOODLIGHT 200W 18000LM 6500K	200	IP65	220-240	≥80	6500K	18.000	90	0,9	F	341*310*36	5
NYV00009BE1R	PANASONIC LED FLOODLIGHT 300W 30000LM 3000K	300	IP66	220-240	≥80	3000K	30.000	100	0,9	F	457*334*42	1
NYV00019BE1R	PANASONIC LED FLOODLIGHT 300W 30000LM 4000K	300	IP66	220-240	≥80	4000K	30.000	100	0,9	F	457*334*42	1
NYV00059BE1R	PANASONIC LED FLOODLIGHT 300W 32000LM 6500K	300	IP66	220-240	≥80	6500K	32.000	107	0,9	F	457*334*42	1



## LED FLOODLIGHT SENSOR

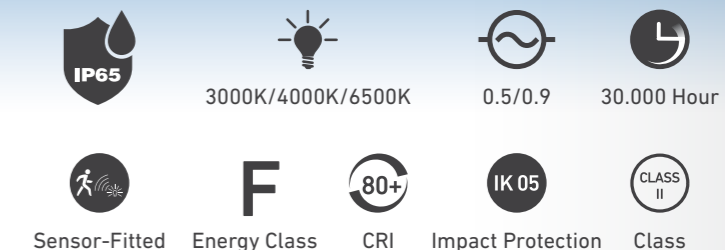

### Product Features:

- Internal radar sensor sensitive to motion and daylight
- Automatic operation at light levels below 20 lux
- Detection area with a height of 6.5 meters, 120° angle, and a diameter of 5 meters
- Automatic shut-off after 30 seconds of no motion detection
- Color options of 3000K/4000K/6500K
- 4 different power options

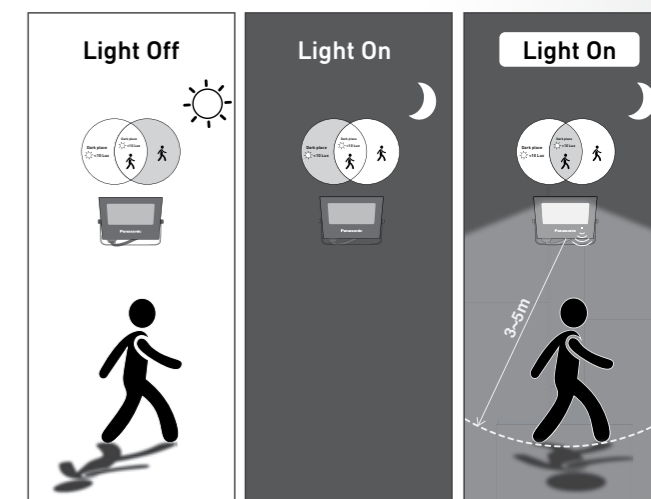

### Application Areas:

- Exterior lighting
- Parking lot
- Factory

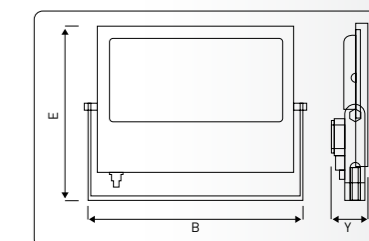
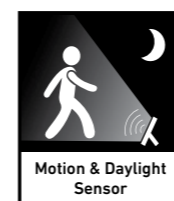

Product Code	Product Description	Power (W)	IP	Operating Voltage (V)	Color Rendering Index (Ra)	Color Temperature	Luminous Flux (lm)	Efficiency Factor (lm/W)	Power Factor (P.F.)	Energy Class	Product Size B*E*Y (mm)	Quantity in Box
NYV00201BE1E	PANASONIC LED FLOODLIGHT SENSOR 10W 820LM 3000K	10	IP65	220-240	≥80	3000K	820	82	0,5	F	101*97*27	30
NYV00211BE1E	PANASONIC LED FLOODLIGHT SENSOR 10W 850LM 4000K	10	IP65	220-240	≥80	4000K	850	85	0,5	F	101*97*27	30
NYV00251BE1E	PANASONIC LED FLOODLIGHT SENSOR 10W 900LM 6500K	10	IP65	220-240	≥80	6500K	900	90	0,5	F	101*97*27	30
NYV00202BE1E	PANASONIC LED FLOODLIGHT SENSOR 20W 1510LM 3000K	20	IP65	220-240	≥80	3000K	1510	76	0,5	F	133*124*29	30
NYV00212BE1E	PANASONIC LED FLOODLIGHT SENSOR 20W 1590LM 4000K	20	IP65	220-240	≥80	4000K	1590	80	0,5	F	133*124*29	30
NYV00252BE1E	PANASONIC LED FLOODLIGHT SENSOR 20W 1660LM 6500K	20	IP65	220-240	≥80	6500K	1660	83	0,5	F	133*124*29	30
NYV00203BE1E	PANASONIC LED FLOODLIGHT SENSOR 30W 2450LM 3000K	30	IP65	220-240	≥80	3000K	2450	82	0,9	F	177*146*28	30
NYV00213BE1E	PANASONIC LED FLOODLIGHT SENSOR 30W 2560LM 4000K	30	IP65	220-240	≥80	4000K	2560	85	0,9	F	177*146*28	30
NYV00253BE1E	PANASONIC LED FLOODLIGHT SENSOR 30W 2560LM 6500K	30	IP65	220-240	≥80	6500K	2560	85	0,9	F	177*146*28	30
NYV00204BE1E	PANASONIC LED FLOODLIGHT SENSOR 50W 4270LM 3000K	50	IP65	220-240	≥80	3000K	4270	85	0,9	F	177*146*28	10
NYV00214BE1E	PANASONIC LED FLOODLIGHT SENSOR 50W 4270LM 4000K	50	IP65	220-240	≥80	4000K	4270	85	0,9	F	177*146*28	10
NYV00254BE1E	PANASONIC LED FLOODLIGHT SENSOR 50W 4270LM 6500K	50	IP65	220-240	≥80	6500K	4270	85	0,9	F	177*146*28	10

# Panasonic LED Ceiling Light

*Brighten your living spaces with modern design.*



## LED CEILING LIGHT

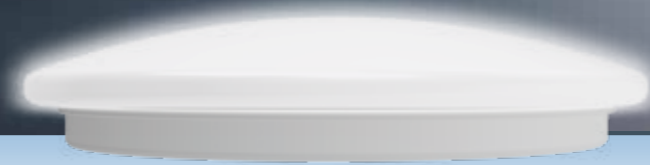







4000K/6500K    0.9    15.000 Hours    Energy Class    CRI    Class

Panasonic LED ceiling light, with its compact size and versatile design, provides a bright lighting experience in various areas such as corridors, entrances, and stairways.

### Product Features:

- Compact size
- Versatile design
- Uniform light distribution

### Application Areas:

- Residential
- Office
- General lighting

Product Code	Product Description	Power (W)	Input Voltage (V)	Ra	CCT	Lumen (lm)	Energy Class	Product Size (mm)	Quantity in Box
HHGXQ143953	PANASONIC LED CEILING LIGHT 13W 900LM 840 Ø235	13	220-240	≥80	4000K	900	F	235*60	20
HHGXQ144053	PANASONIC LED CEILING LIGHT 13W 900LM 865 Ø235	13	220-240	≥80	6500K	900	F	235*60	20
HHGXQ244153	PANASONIC LED CEILING LIGHT 24W 1800LM 840 Ø285	24	220-240	≥80	4000K	1800	F	235*60	20
HHGXQ244253	PANASONIC LED CEILING LIGHT 24W 1800LM 840 Ø285	24	220-240	≥80	6500K	1800	F	235*60	20

# Panasonic USB Desk Lamp



## USB DESK LAMP

 3000K/4000K/5000K
  0.9
  20.000 Hours
  Energy Class F
  80+ CRI
  CLASS II

The Panasonic USB Desk Lamp, designed with a specially crafted foldable structure for ease of use, can be turned on and off with a single touch via its touch-sensitive switch and can be adjusted to the desired light temperature.

### Product Features:

- Dimmable & Color adjustable
- Convenient USB charging
- Flexibility & Portability
- Phone-holder

### Application Areas:

- Students
- Home office
- Reading or other hobbies

Product No	Product Description	Power (W)	Input Voltage (V)	Ra	CCT	Lumen (lm)	Energy Class	Product Size (mm)	Net Weight (g)	Size (mm)	Quantity in Box
HHGLT0339BU32	PANASONIC LED DESK LAMP 3000/4000/5000K USB BLACK	3,5	DC5V	≥80	3000/4000/5000K	>30	F	74*52*266	480	535*440*330	25
HHGLT0339WU32	PANASONIC LED DESK LAMP 3000/4000/5000K USB WHITE	3,5	DC5V	≥80	3000/4000/5000K	>30	F	74*52*266	480	535*440*330	25

## Panasonic LED Downlight

Easy installation, high efficiency, long lasting, in professional areas and residential/dwelling.



### LED DOWNLIGHT

 3000K/4000K/6500K
  0.5/0.9
  15.000 Hour
  CRI
  Class II

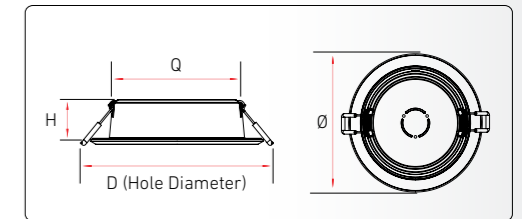

Product Code	Product Description	Power (W)	Input Voltage (V)	Ra	CCT	Lumen (lm)	Product Size D*Q*H (mm)	Quantity in Box
NNV70830WE1E	PANASONIC SDN LUMINAIRE 6W 450LM 830 Ø90	6	220-240	≥80	3000K	450	D109*Ø90*32	40
NNV70840WE1E	PANASONIC SDN LUMINAIRE 6W 480LM 840 Ø90	6	220-240	≥80	4000K	480	D109*Ø90*32	40
NNV70860WE1E	PANASONIC SDN LUMINAIRE 6W 480LM 865 Ø90	6	220-240	≥80	6500K	480	D109*Ø90*32	40
NNV70831WE1E	PANASONIC SDN LUMINAIRE 8W 600LM 830 Ø90	8	220-240	≥80	3000K	600	D109*Ø90*32	40
NNV70841WE1E	PANASONIC SDN LUMINAIRE 8W 640LM 840 Ø90	8	220-240	≥80	4000K	640	D109*Ø90*32	40
NNV70861WE1E	PANASONIC SDN LUMINAIRE 8W 640LM 865 Ø90	8	220-240	≥80	6500K	640	D109*Ø90*32	40
NNV70832WE1E	PANASONIC SDN LUMINAIRE 12W 900LM 830 Ø110	12	220-240	≥80	3000K	900	D129*Ø110*32	40
NNV70842WE1E	PANASONIC SDN LUMINAIRE 12W 960LM 840 Ø110	12	220-240	≥80	4000K	960	D129*Ø110*32	40
NNV70862WE1E	PANASONIC SDN LUMINAIRE 12W 960LM 865 Ø110	12	220-240	≥80	6500K	960	D129*Ø110*32	40
NNV70833WE1E	PANASONIC SDN LUMINAIRE 15W 1125LM 830 Ø125	15	220-240	≥80	3000K	1.125	D144*Ø125*32	30
NNV70843WE1E	PANASONIC SDN LUMINAIRE 15W 1200LM 840 Ø125	15	220-240	≥80	4000K	1.200	D144*Ø125*32	30
NNV70863WE1E	PANASONIC SDN LUMINAIRE 15W 1200LM 865 Ø125	15	220-240	≥80	6500K	1.200	D144*Ø125*32	30
NNV70834WE1E	PANASONIC SDN LUMINAIRE 18W 1350LM 830 Ø150	18	220-240	≥80	3000K	1.350	D169*Ø150*32	30
NNV70844WE1E	PANASONIC SDN LUMINAIRE 18W 1440LM 840 Ø150	18	220-240	≥80	4000K	1.440	D169*Ø150*32	30
NNV70864WE1E	PANASONIC SDN LUMINAIRE 18W 1440LM 865 Ø150	18	220-240	≥80	6500K	1.440	D169*Ø150*32	30
NNV70835WE1E	PANASONIC SDN LUMINAIRE 24W 1800LM 830 Ø175	24	220-240	≥80	3000K	1.800	D194*Ø175*32	30
NNV70845WE1E	PANASONIC SDN LUMINAIRE 24W 1920LM 840 Ø175	24	220-240	≥80	4000K	1.920	D194*Ø175*32	30
NNV70865WE1E	PANASONIC SDN LUMINAIRE 24W 1920LM 865 Ø175	24	220-240	≥80	6500K	1.920	Ø194*Ø175*32	30

### Accessories

Product No	Description	Corresponding Prpduct Size (mm)	Product Size (mm)	Net Weight (g)	Individual Box Gross Weight (g)	Outer Carton Qty (pcs)	Corresponding Downlight
NNV9000WM1E	Surface Mounting Frame for DL	Cut-out Ø90 6W	Ø109*H45	62	93	20	NNV70830WE1E, NNV70840WE1E, NNV70860WE1E NNV70831WE1E, NNV70841WE1E, NNV70861WE1E
		Cut-out Ø90 9W					
NNV90001WM1E	Surface Mounting Frame for DL	Cut-out Ø110 9W	Ø114*H45	74	117	20	NNV70832WE1E, NNV70842WE1E, NNV70862WE1E
		Cut-out Ø110 12W					
NNV90002WM1E	Surface Mounting Frame for DL	Cut-out Ø125 12W	Ø144*H45	77	123	20	NNV70833WE1E, NNV70843WE1E, NNV70863WE1E
		Cut-out Ø125 15W					
NNV90003WM1E	Surface Mounting Frame for DL	Cut-out Ø150 15W	Ø170*H45	91	144	20	NNV70834WE1E, NNV70844WE1E, NNV70864WE1E
		Cut-out Ø150 18W					
NNV90004WM1E	Surface Mounting Frame for DL	Cut-out Ø175 18W	Ø194*H45	107	180	20	NNV70835WE1E, NNV70845WE1E, NNV70865WE1E
		Cut-out Ø175 24W					



We have been working for a more liveable life for more than 100 years.



Panasonic Electric Works Elektrik San. ve Tic. A.Ş.

Abdurrahmangazi Mah. Ebubekir Cad. No: 44 34887 Sancaktepe İstanbul / Türkiye  
T: +90 (216) 564 55 55 F: +90 (216) 564 55 44 ewtr.panasonic.com info@tr.panasonic.com

**Panasonic**