

## WRKT33305WH KNX MODULAR THERMOSTAT WHITE BACKLIGHT

WRKT33305WH



Installation should only be carried out by a technical personnel having certificate of competency

# Panasonic®

Panasonic Electric Works Elektrik San.ve Tic. A.Ş.  
Abdurrahmangazi Mah. Ebubekir Cad. No: 44  
34887 Sancaktepe / İstanbul / Turkey  
T: 0(216) 564 55 55 F: 0(216) 564 55 44

**HOTLINE**  
**444 8456**

ewtr.panasonic.com

611077-KNX-EN

### Installation

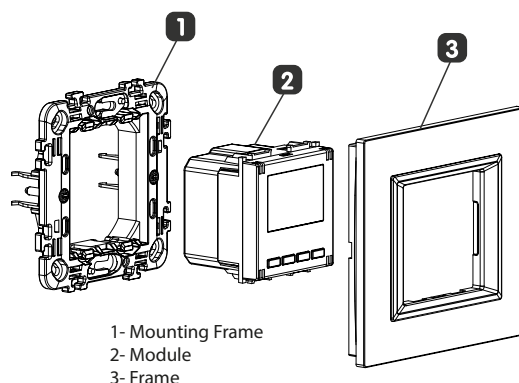

Connect the cables, according to the connection diagram 1. Place the mounting frame (1) in the mounting box and fix the screws with an appropriate screwdriver. Place the module (2) to the mounting frame (1) with the help of clips. Fix the frame (3) to the mounting frame (1).

### Product Components

#### Modular Thermostat

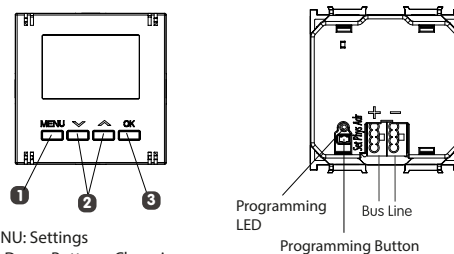

### Technical Data

Programming Mode	S Mode
Operating voltage	DC 21-32 V (from KNX bus)
Ambient temperature	-10 °C... + 55°C
Storage temperature	-5 °C... + 45°C
Ambient humidity	5...93% (non-condensing)
Maximum current consumption	Max 10 mA
KNX bus connection	KNX connector (243-211 Wago)

### WARNING

- Ensure that the power is cut off before the assembly of the products.
- Connection and assembly of the electrical devices should be carried out only by the technical personnel having certificate of competency.
- No responsibility is assumed for the entire of the malfunction, accident and loss arising from the assembly or interference of the persons not having the competency certificate.
- Use dry or slightly damp cloth to clean the buttons, cover and frame of the product. Never use alcohol, cologne, detergent or other similar chemicals for cleaning. Do not perform wet cleaning do not contact the product with water when the product is energized.
- In case the surface to which the product is connected is dyed, store the product by removing its cover and the frames.
- Keep the product away from the damp or wet environment during the transportation and shipping.
- It is intended for indoor use only.

### Dimensional Drawings

#### • Thermostat module

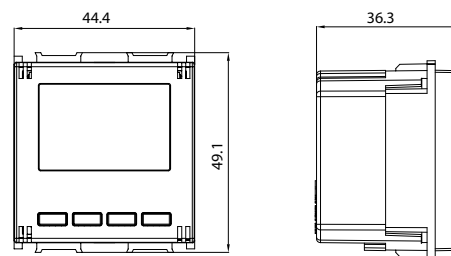

#### • Mounting frame

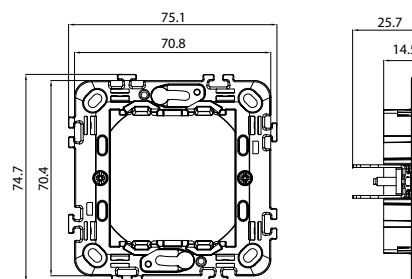

### Service and Guarantee

- Warranty period starts as of the delivery date of the product and it is 2 years.
- Warranty covers the malfunctions likely to occur due to the manufacturing defects of the product and within the warranty period.
- The product including all of its parts is under warranty as a whole. If the product turns out to be defective, the consumer can use one of the following rights stipulated in Article 11 of Consumer Protection Law no. 6502;
  - Withdrawal from the contract
  - Demanding discount from sales fee
  - Demanding free repair,
  - Demanding the replacement of the sold one with a fungible one free from defects.
- In case the consumer chooses the right of free repair among those rights; the dealer is obliged to repair the product or have the product repaired without claiming any fee under the name of replaced part fee, labor cost or for any other reasons. The consumer can also use the right of free repair against the manufacturer or exporter. The dealer, manufacturer and exporter are jointly and severally liable for the usage of this right by the consumer.
- In case the consumer uses the right of free repair and if the product
  - fails within the warranty period again and
  - the maximum period required for the repair is exceeded and
- Authorized service station, dealer, manufacturer or exporter state that it's not possible to repair the product in a report, the consumer can demand the return of the product fee, fee discount at the ratio of the defect or the replacement with the one free of defects, if possible, from the dealer. The dealer can not reject the demand of the consumer. In case this demand is not met, the dealer, manufacturer and exporter shall jointly and severally be held responsible.
- The repair period of the product can not exceed 20 business days. This period starts on the notification of the failure on the product to the authorized service station or the dealer within the warranty period and from the date of delivery of the product to the authorized service station out of warranty period. In case of not eliminating the product malfunction within 10 business days, manufacturer or importer is obliged to dedicate another product with similar characteristics to the use of the consumer until the completion of the product repair. In case the product fails within the warranty period, elapsed time is added to the warranty period.
- Usage of the product contrary to the rules stipulated in user's manual, operating out of determined voltage, current and environmental conditions, damage on the cable connection due to the user's fault and failure of the product due to the facts arising from the fire, flood, earthquake, lightning and similar disasters are not under warranty.
- The consumer can apply to the arbitration committee for consumers or the consumer court where the consumer operations are made or in the residential area for the disputes to be occurred regarding the usage of the rights arising from the warranty.
- In case the dealer doesn't provide this certificate of warranty, the consumer can apply to the General Directorate of Consumer Protection and Market Surveillance of Ministry of Customs and Trade".

### General Features

Room temperature controller senses the current room temperature and controls the heating and/or cooling system.

Device has 2 different weekly switching programs which can be programmed separately by user.

The display is backlighted for reading easily. The Room temperature controller is fitted with push-switches and an LCD to show and change the current operating modes and values. The room temperature controller does not require an auxiliary power supply. The Engineering Software Tool (from ETS) is used to assign the physical address and set the parameters.

The following functions can be done using the thermostat.

- Comfort / standby / night-economy / building protection mode
- Fan control
- Heating/Cooling mode control
- Set date/time
- 2 different weekly program
- Backlight

Comfort mode: Heater/Cooler at normal level.  
Standby mode: Heater/Cooler at slightly reduced.  
Night/Economy mode: Heater/Cooler power is considerably reduced.

Building Protection mode: Prevent the room for freezing or overheating.