

WRKT32305NC

KNX High Bay Mount Presence Detector

WRKT32305NC



Installation should only be carried out by a technical personnel having certificate of competency

Panasonic®

Panasonic Electric Works Elektrik San.ve Tic. A.Ş.
Abdurrahmangazi Mah. Ebubekir Cad. No: 44
34887 Sancaktepe / İstanbul / Turkey
T: 0(216) 564 55 55 F: 0(216) 564 55 44

HOTLINE
444 8456

ewtr.panasonic.com

1. Main Features

KNX High Bay Mount Presence Detector integrated both PIR motion and light level detector, solely designed for incorporating to the KNX Home and Building Control System to be applied in lighting and HVAC control to achieve automation control and energy saving.

- The presence detector is used to control devices, such as: Lighting, HVAC, Alarm.
- For use in KNX (EIB), TP (twisted pair) bus system in conjunction with other KNX components.
- Parameter and function settings via ETS 5 (Engineering Tool Software Ver.5.0).
- High bay design allows to be mounted up to 10m height.
- Available in various mounting methods, e.g. surface mount with junction box and flush mount with power box cap both applicable, and can be fitted into the European standard junction box.

2. Technical Specifications

Rated Voltage	21 - 30VDC (supply by KNX bus)
Current Consumption EIB / KNX	Operate: Approx. 10mA Standby: Approx. 5mA
Connection Type	Bus connection terminal Φ 0.8mm, single core
Output	5 channels (2 channels for lighting 2 channels for HVAC 1 channel for Alarm)
Settings	Settable by ETS
Detection Range	360° circular, up to Ø8m at height of 2.5m, up to Ø 16m at height of 10m
Sensitivity	Adjustable via ETS in 4 steps
Light Measuring	10 - 2000Lux

Operating Temperature	-20°C to +50°C
Environmental Protection	IP20
Standard and Safety	EN 61000-6-1 / EN 61000-6-3 / EN 55014 / EN 50491

Table-1

3. Usage of Lens Shield

3.1. KNX High Bay Mount Presence Detector has provided 2 lens shields for masking the undesired detection area. Each lens shield has 3 layers (Layer A / Layer B / Layer C), each layer includes 6 small segments and each small segment can cover 30° detection angle. For example, install the detector at the height of 10m, the detection range is as below:

Used lens shield	Covered detection range
None	Ø 16m
Small segment	30° per piece
A+B+C	Ø 1m
A+B	Ø 12m
A	Ø 14m

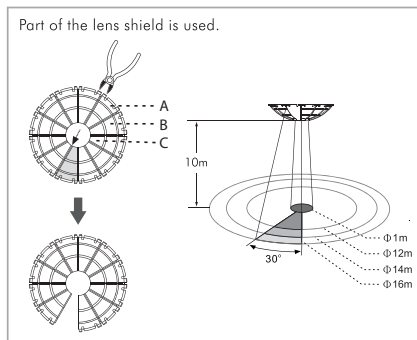

FIG.1

The shadow part of the lens shields in the FIG.1 is referring to the cut off parts.

3.2. After user choosing the desired detection area, the redundant lens shield should be eliminated.

3.3. Fixing lens shield: There is slot around the lens and insert the lens shield into slot (See FIG. 2).

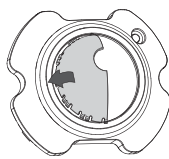

FIG.2

4. Installation

4.1 Select a proper location

4.1.1. KNX High Bay Mount Presence Detector can be installed between the height of 2.5 m to 10 m. However, it's recommended to be installed at the height of 10 m to gain the optimal detection pattern reaching up to the detection coverage of 16 m diameter and 360° detection angle (See FIG. 3-A & FIG. 3 - B).

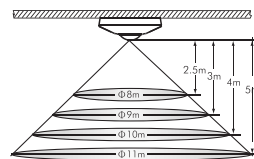

FIG. 3-A

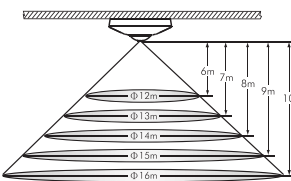

FIG. 3-B

4.1.2. Pay attention to the walking direction in the test proceeding. It is more sensitive to movement across the detector and less sensitive to movement directly toward to detector which will reduce the detection coverage (See FIG. 4).

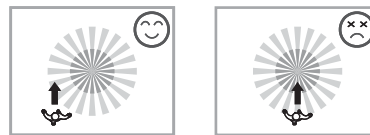

FIG. 4

4.1.3. Helpful tips for installation

Since the detector is in response to temperature change, please avoid the following conditions (See FIG. 5-A & FIG. 5-B):

- Avoid pointing the detector toward the objects which surfaces are highly reflective, such as mirror, glass, etc.
- Avoid mounting the detector near heat sources, such as heating vents, air conditioners, lights, etc.
- Avoid aiming the detector toward the objects which may be swayed in the wind, such as curtain, tall plants, etc.

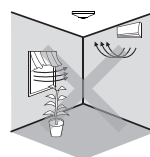

FIG. 5-A

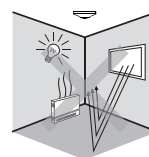

FIG. 5-B

4.2. Installation procedure

4.2.1. Flush mount with European standard junction box

4.2.1.1. Take off decorative frame of KNX High Bay Mount Presence Detector (See FIG.6).

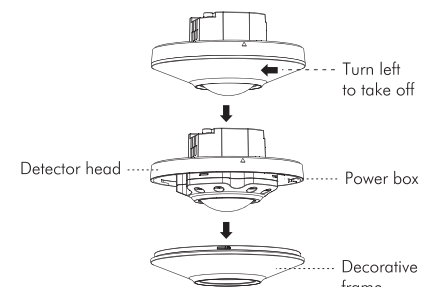

FIG.6

4.2.1.2. Pull out KNX bus cable from European standard junction

4.2.1.3. Connect the bus cables (See FIG. 6-A) The bus terminal consists of two components (B2.1, B2.2) with four terminal contacts each. It can be used with solid conductors, Ø 0.6 ... 0.8 mm. Strip off 5mm of cable sheathing and insert in the terminal (red = +, grey = -).

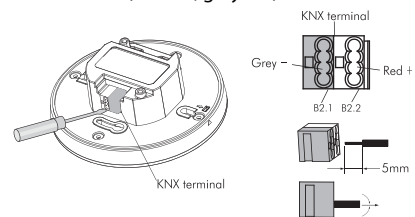

FIG. 6 -A

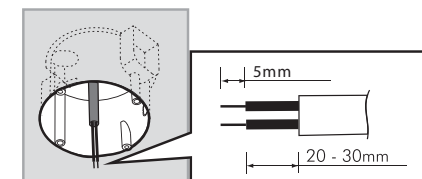

FIG. 6-B

4.2.1.4. Please refer to illustration of FIG.7 for correct wiring and fix the power box into European standard junction box with 2 pcs screws (See FIG. 8).

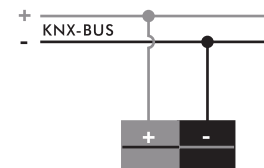

FIG. 7

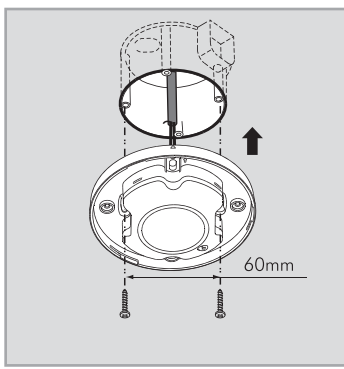
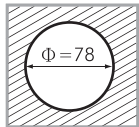

FIG.8

4.2.1.5. Fix the decorative frame (See FIG.6).
4.2.1.6. Restore the power supply.

4.2.2. Flush mount with power box cap (Optional purchase)

4.2.2.1. To install the detector, please drill a hole with diameter of 78 mm on ceiling board and keep the cable outside.
Then, refer to Section 4.2.1.2. to 4.2.1.3. for cable connection (See FIG. 9).



Drill a hole with $\Phi = 78\text{mm}$ on the ceiling

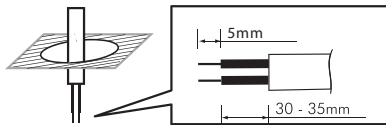

FIG.9

4.2.2.2. Use a screwdriver to break the rubber gasket on power box cap, then feed cables through it (See FIG. 10).

4.2.2.3. Please refer to illustration of FIG.7 for correct wiring and then screw the power box cap tightly.

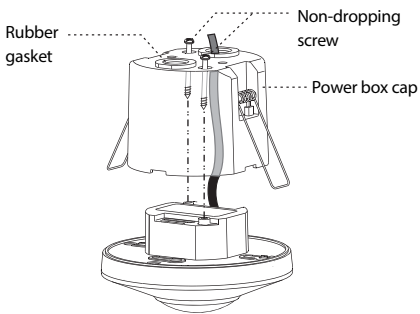

FIG.10

4.2.2.4. Close up two spring clips of detector and insert the detector in to the drilled hole on ceiling (See FIG.11).

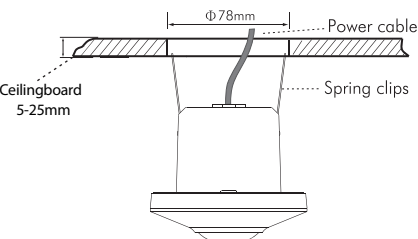

FIG.11

4.2.2.5. Restore the power supply.

4.2.3. Surface mount with junction box (Optional purchase)

4.2.3.1. There are 4 pairs of knock outs with various distances from 56 mm to 80 mm on the bottom cover of combined junction box can be selected for different mounting applications (See FIG.12). Select two same figures on both ends for the corresponding distance for fixing (See Table-2).

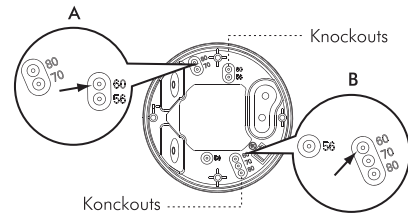

FIG.12

NO.	A	B	The distance between A and B
1	56	56	56mm
2	60	60	60mm
3	70	70	70mm
4	80	80	80mm

Table-2

4.2.3.2. To feed cables through the side of junction box, please use the cutting pliers to break the cable entry knock outs on the side of junction box, then insert cables into junction box and feed through it. Then, refer to Section 4.2.1.2. to 4.2.1.3. for cable connection.

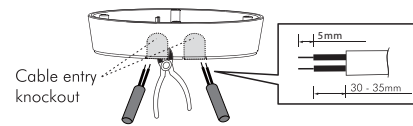

FIG.13

4.2.3.3. Choose proper knock outs to fix the junction box on the surface of ceiling board with 2 pcs wood screws attached with rubber washer (See FIG.14).

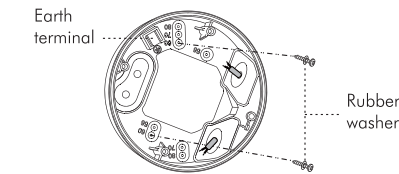

FIG.14

4.2.3.4. Refer to wiring diagrams for correct wiring (See FIG. 7).

There is a square hole in the fixing plate, when you put the fixing plate into the junction box, please fit the fillister to the protrusion on junction box (See FIG.15), then fix the detector head on the power box (See FIG.6) with the attached 4 pcs non-dropping screws.

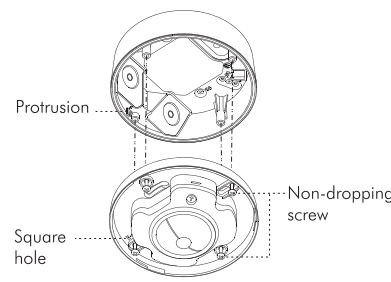

FIG.15

4.2.3.5. Cover back the decorative frame of detector and restore the power supply.

5. Trouble Shooting

When KNX High Bay Mount Presence Detector works abnormally, check assumptive problems and suggested solutions in following table that will hopefully solve your problem.

Problem	Possible cause	Suggested Solution
Lighting / HVAC device does not turn on	1. Power does not turn on.	1. Switch on the power.
	2. Incorrect wiring	2. Refer to wiring diagrams for correct connection.
	3. Incorrect Lux setting.	3. Check if Lux is set to the correct position.
	4. Malfunctioned load.	4. Replace the disabled load with a new one.
	5. Unable to detect movement.	5. Check detection range setting.
Lighting / HVAC device does not turn off	1. Auto off time is set too long.	1. Set auto off time to a shorter time and check if the load is switched off or not according to the pre-set delay off time.
	2. Detector is nuisance triggered.	2. Keep be away from detection coverage to avoid activating detector while doing the test.
	3. Incorrect wiring	3. Refer to wiring diagrams for correct connection.
Red LED does not turn on	1. Not set to Test mode.	1. Set to test mode.
	2. Exceeding the detection range.	2. Walk in the effective detection range of $\Phi 16\text{m}$.
	3. LED indicating function is set to "Disable".	3. Set the LED indicating function to "Enable" via ETS software.
Nuisance triggered	There are heat sources, highly reflective objects or any objects which may be swayed in the wind within the detection coverage.	Avoid aiming the detector towards any heat sources, such as air conditionings, electric fans, heaters or any highly reflective surfaces. Make sure there are no swaying objects within the detection coverage.

6. Dimensional Drawings

KNX High Bay Mount Presence Detector

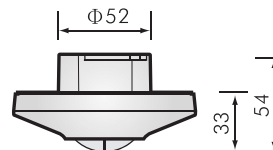
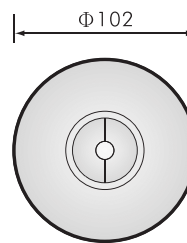

• Detector with junction box

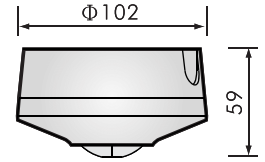

• Detector with power box cap

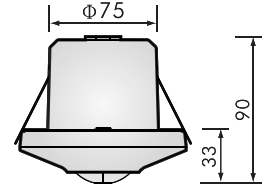

7. Warning

- Ensure that the power is cut off before the assembly of the products.
- Connection and assembly of the electrical devices should be carried out only by the technical personnel having certificate of competency.
- No responsibility is assumed for the entire of the malfunction, accident and loss arising from the assembly or interference of the persons not having the competency certificate.
- Use dry or slightly damp cloth to clean the buttons, cover and frame of the product. Never use alcohol, cologne, detergent or other similar chemicals for cleaning. Do not perform wet cleaning do not contact the product with water when the product is energized.
- In case the surface to which the product is connected is dyed, store the product by removing its cover and the frames.
- Keep the product away from the damp or wet environment during the transportation and shipping.
- It is intended for indoor use only.

8. Service and Guarantee

- Warranty period starts as of the delivery date of the product and it is 2 years.
- Warranty covers the malfunctions likely to occur due to the manufacturing defects of the product and within the warranty period.
- The product including all of its parts is under warranty as a whole. If the product turns out to be defective, the consumer can use one of the following rights stipulated in Article 11 of Consumer Protection Law no. 6502;
 - Withdrawal from the contract
 - Demanding discount from sales fee
 - Demanding free repair,
 - Demanding the replacement of the sold one with a fungible one free from defects.
- In case the consumer chooses the right of free repair among those rights; the dealer is obliged to repair the product or have the product repaired without claiming any fee under the name of replaced part fee, labor cost or for any other reasons. The consumer can also use the right of free repair against the manufacturer or exporter. The dealer, manufacturer and exporter are jointly and severally liable for the usage of this right by the consumer.
- In case the consumer uses the right of free repair and if the product
 - fails within the warranty period again and
 - the maximum period required for the repair is exceeded and
 - Authorized service station, dealer, manufacturer or exporter state that it's not possible to repair the product in a report, the consumer can demand the return of the product fee, fee discount at the ratio of the defect or the replacement with the one free of defects, if possible, from the dealer. The dealer can not reject the demand of the consumer. In case this demand is not met, the dealer, manufacturer and exporter shall jointly and severally be held responsible.
- The repair period of the product can not exceed 20 business days. This period starts on the notification of the failure on the product to the authorized service station or the dealer within the warranty period and from the date of delivery of the product to the authorized service station out of warranty period. In case of not eliminating the product malfunction within 10 business days, manufacturer or importer is obliged to dedicate another product with similar characteristics to the use of the consumer until the completion of the product repair. In case the product fails within the warranty period, elapsed time is added to the warranty period.
- Usage of the product contrary to the rules stipulated in user's manual, operating out of determined voltage, current and environmental conditions, damage on the cable connection due to the user's fault and failure of the product due to the facts arising from the fire, flood, earthquake, lightning and similar disasters are not under warranty.
- The consumer can apply to the arbitration committee for consumers or the consumer court where the consumer operations are made or in the residential area for the disputes to be occurred regarding the usage of the rights arising from the warranty.
- In case the dealer doesn't provide this certificate of warranty, the consumer can apply to the General Directorate of Consumer Protection and Market Surveillance of Ministry of Customs and Trade".