

PRODUCT DATASHEET



Product Name : K/M 2P+E (French Type) UPS Socket Mechanism+Cover

Product Code : 90967045

Product Series : Karre/Meridian

Technical Specifications:

Rated Current : 16AX, 250V~

Material : ABS (Acrylonitrile Butadine-Styrene)

Colour Options : White, Beige

Certificates : TSE, VDE, NF, EAC, CE, WEEE

Cable Standard:

Cable Diameter : 1,5mm²-2,5mm²

Applicable Cable: Solid Wire, Stranded Wire



Circuit Diagram:

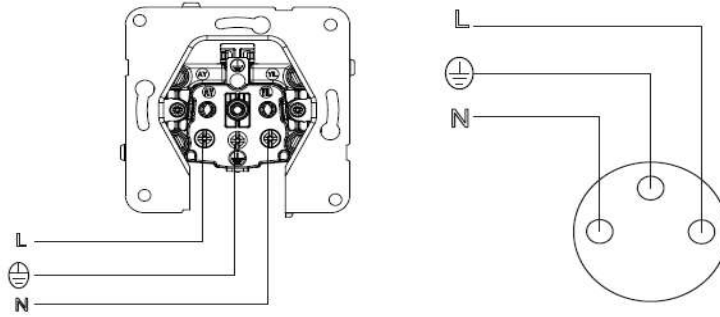

Dimensions:

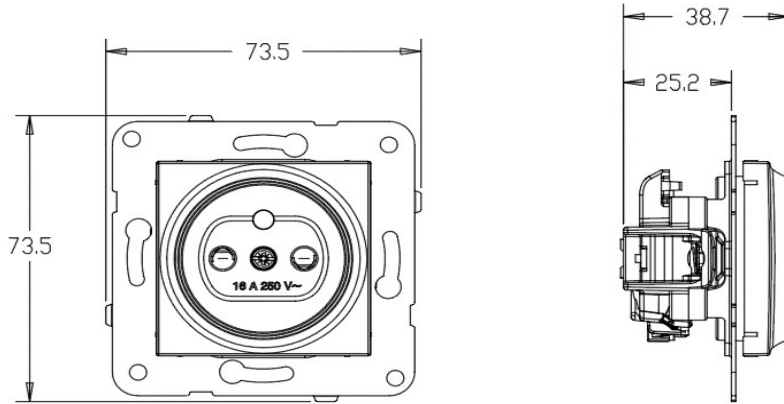

Panasonic Electric Works Elektrik.San. ve Tic. A.Ş.

Abdurrahmangazi Mah. Ebubekir Cad. No: 44 Sancaktepe / İstanbul Tel: 0216 564 55 55 Fax: 0216 564 55 44

ewtr.panasonic.com