

PRODUCT DATASHEET

V:KO
by **Panasonic**

Product Name : Motion Sensor 3W (V2)

Product Code : 90961072

Product Series : Karre/Meridian

Technical Specifications:

Sensing Angle :	180° Horizontal
Sensing Distance :	5m max.
Supply Voltage :	230 VAC ~ ± 10 % , 50 Hz
Operating Temperature :	0 ~ +35°C
Mounting Height :	1m ... 2m
Inrush Current :	Max. 20ms (For Glow Filament Lamps) 80A
Daylight Setting :	5...250 Lux



Load Types :	For incandescent lamps	2300 W
	For halogen lamps with mechanical transformer	1500VA
	For halogen lamps with electronic transformer	1500VA
	For CFL lamps	1500VA

Material : ABS (Acrylonitrile Butadine-Styrene)

Colour Options : White, Beige

Certificates : CE

Connection Diagram:

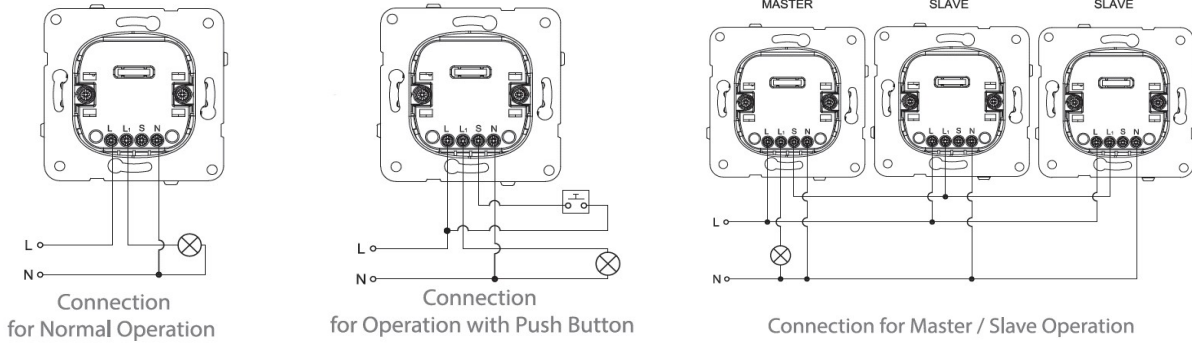

Dimensions:

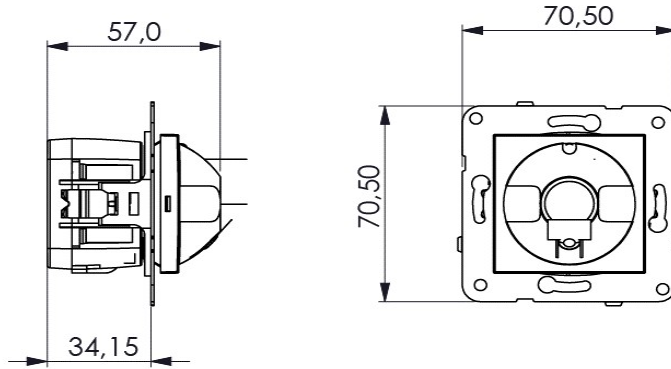

Panasonic Electric Works Turkey Elektrik.San. ve Tic. A.Ş.
Abdurrhmanğazi Mah. Ebubekir Cad. No: 44 Sancaktepe / İstanbul Tel: 0216 564 55 55 Fax: 0216 564 55 44
ewtr.panasonic.com